

THE AVERAGE PROPORTIONS IN THE ADULT MALE FIGURE.

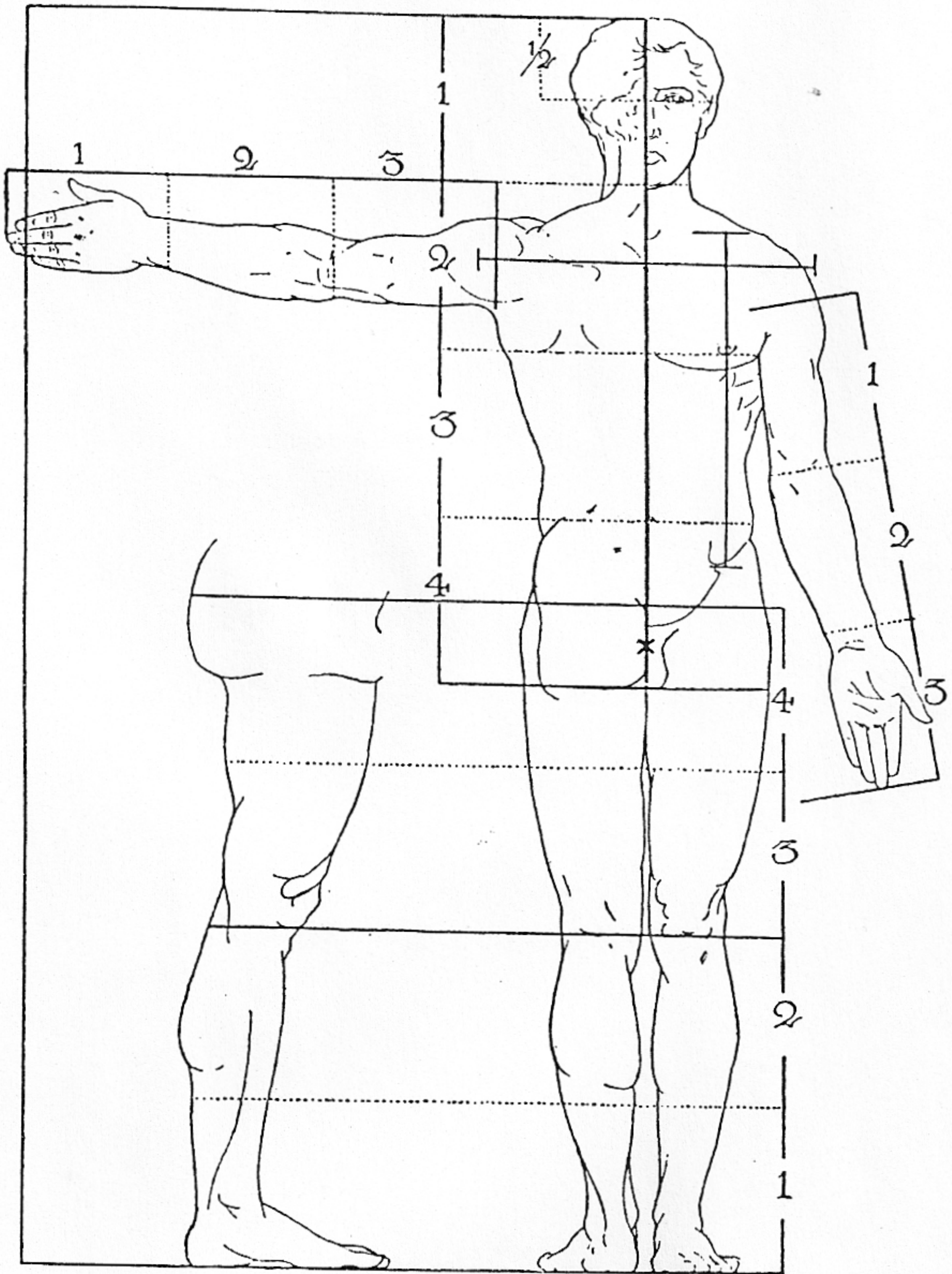

The divisions indicate head-lengths. X marks the middle of the body. (From Richer.)

THE AVERAGE PROPORTIONS IN THE ADULT FEMALE FIGURE.

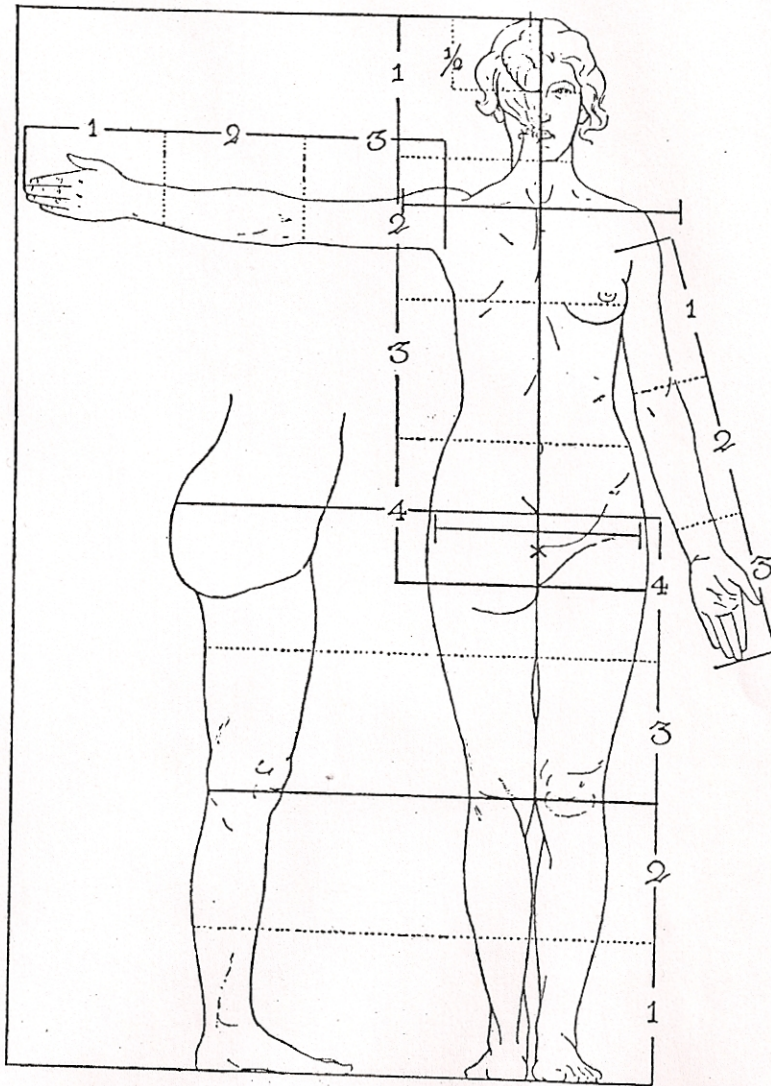

The divisions indicate head-lengths. X marks the middle of the body. (From Richer.)

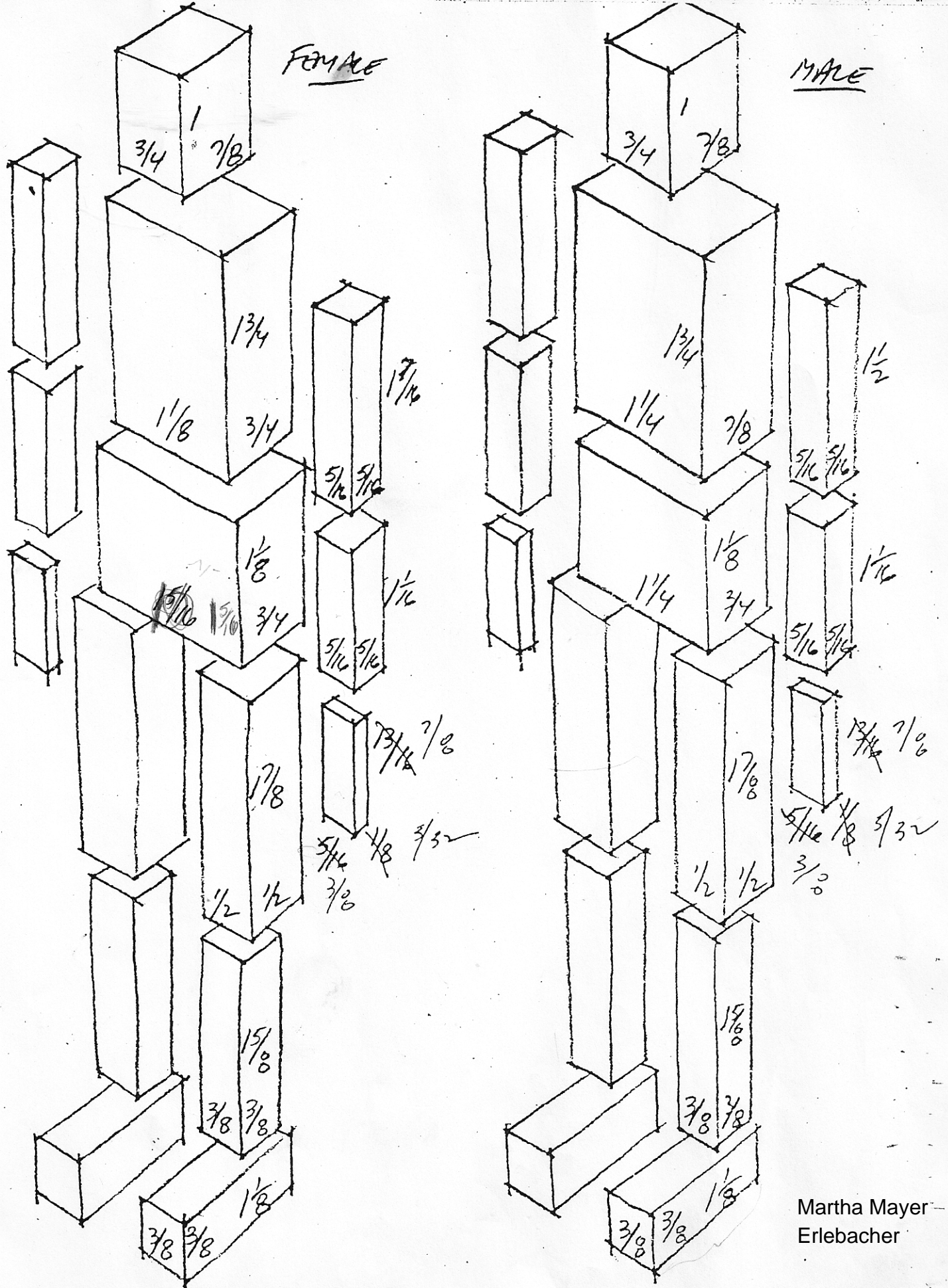

Martha Mayer-
Erlebacher

6) PROPORTIONS OF THE FIFTEEN BASIC RECTANGULAR VOLUMES

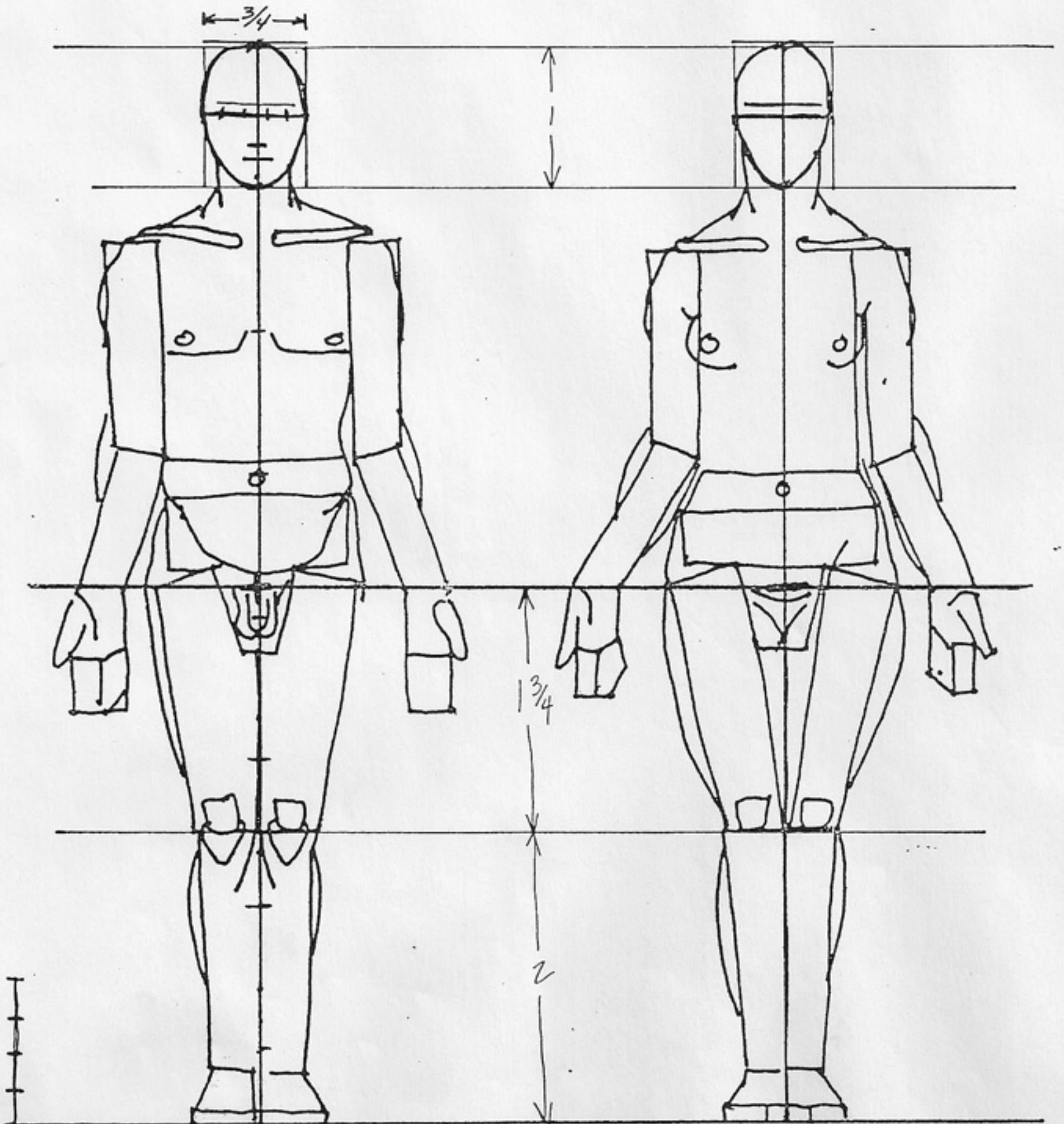

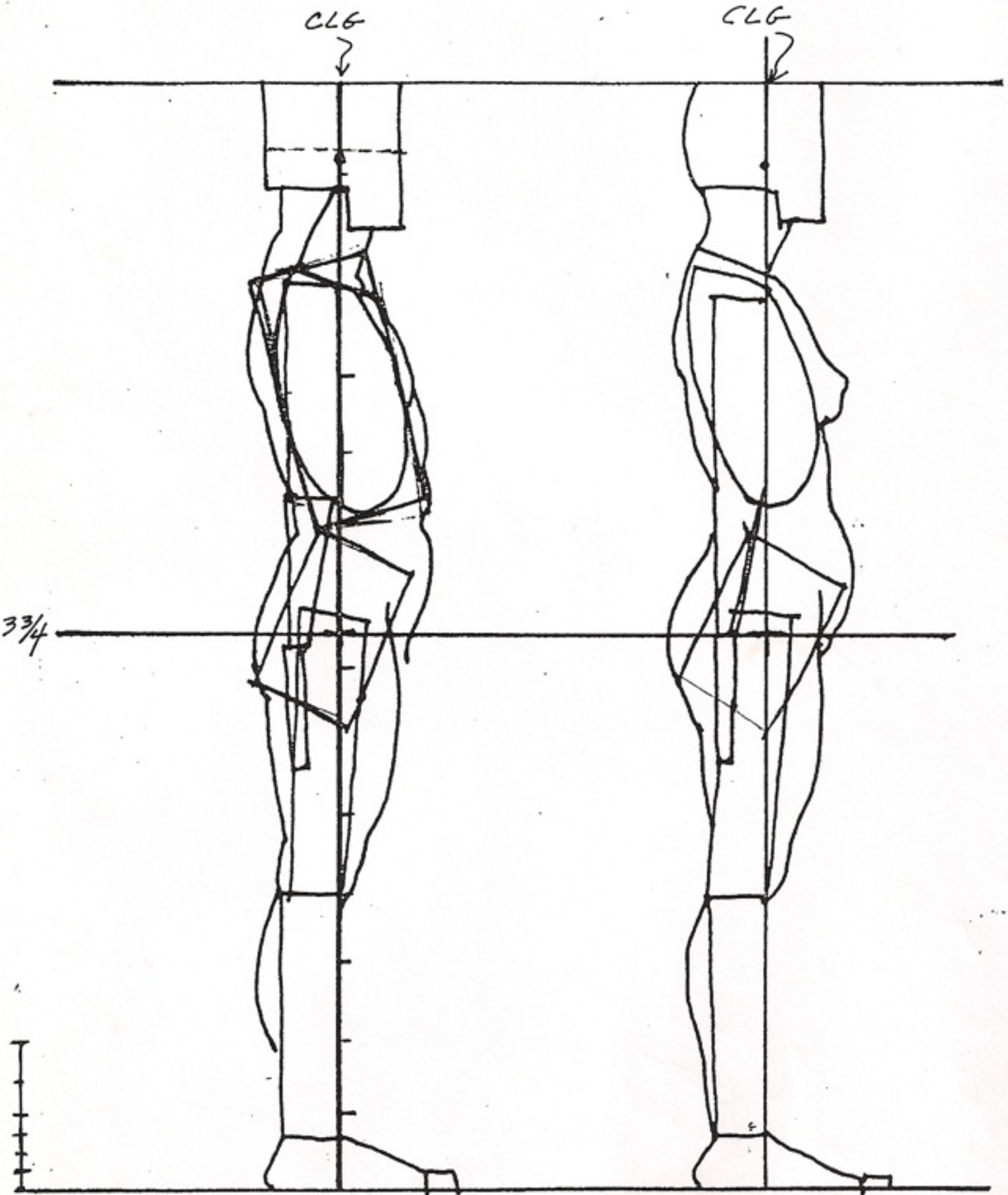

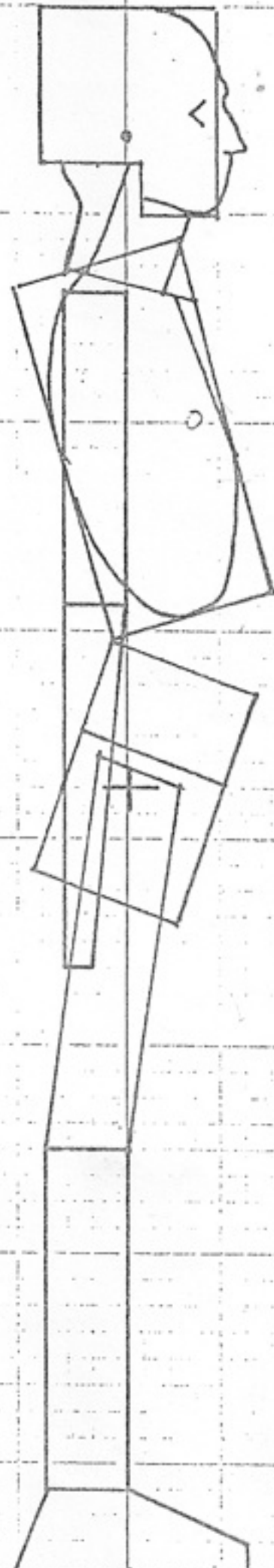
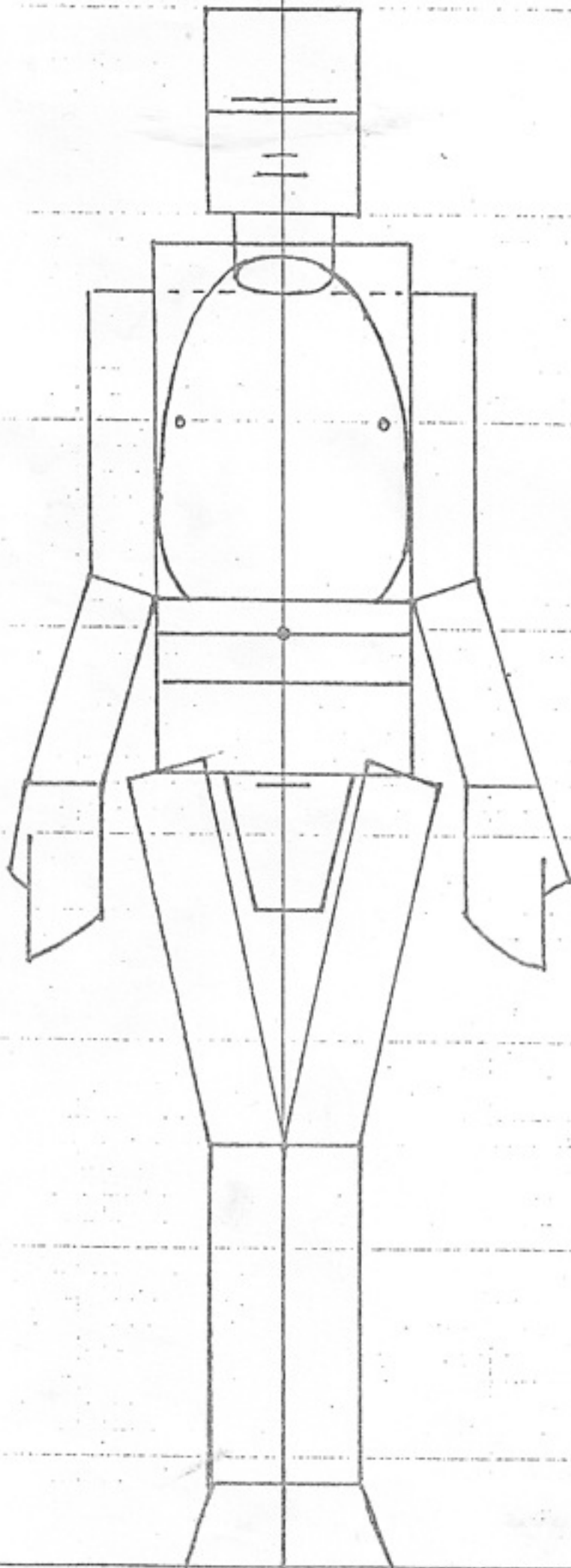

MALE.

Martha Mayer Erlebacher

CLG

3/4

1 head

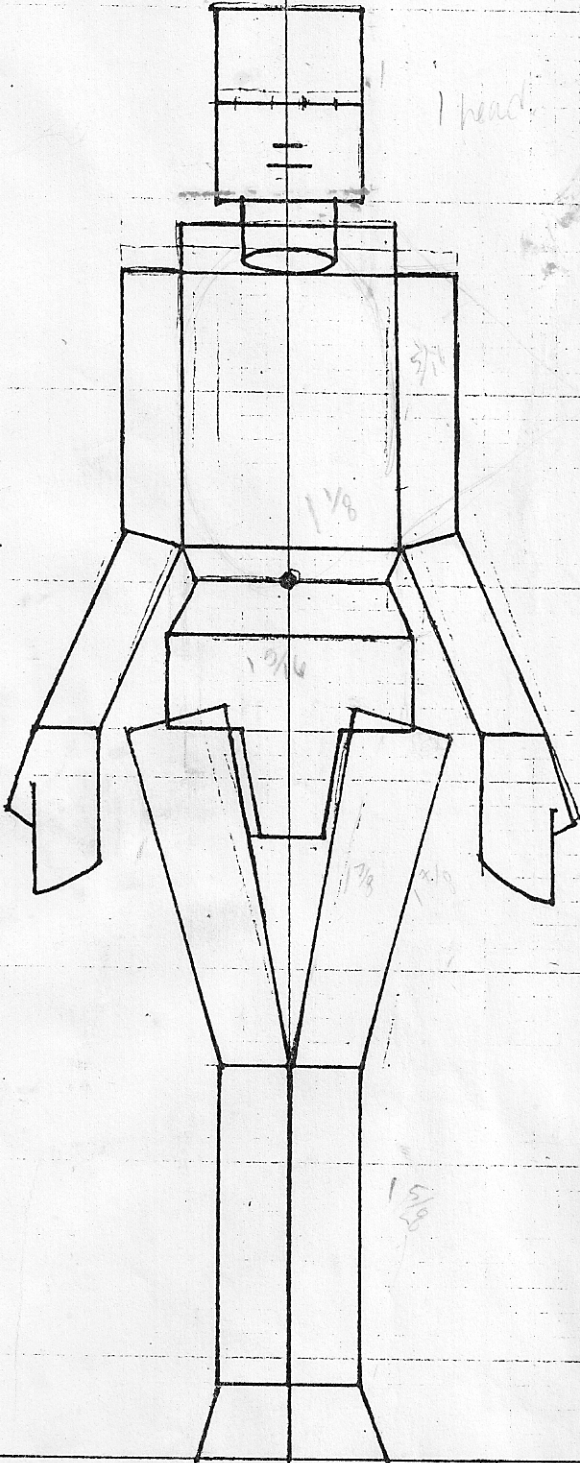

CLG

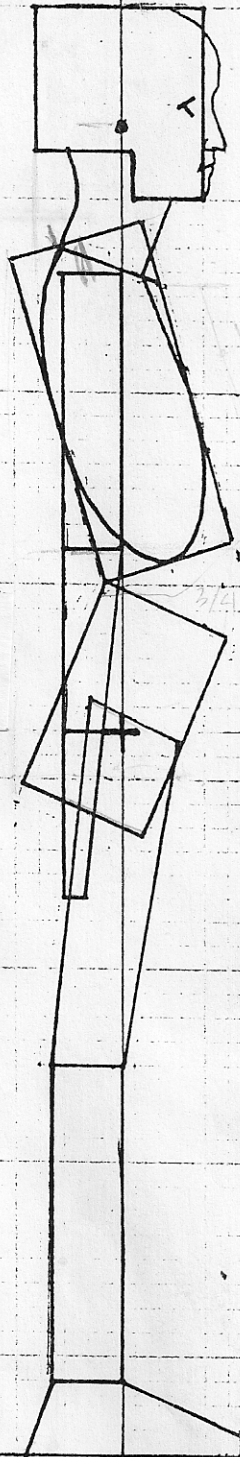

FEMALE

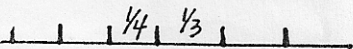

Martha Mayer Erlebacher

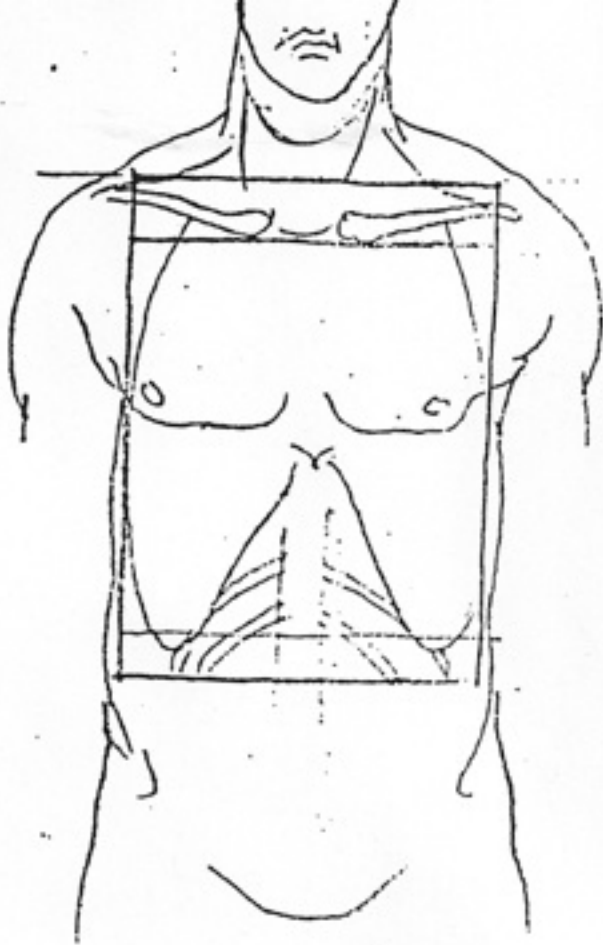

MALE

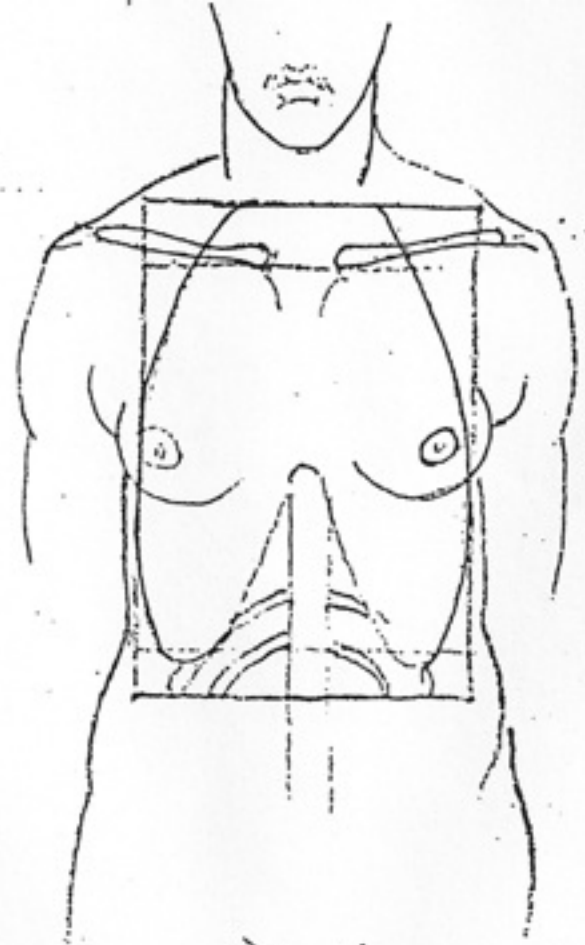

FEMALE

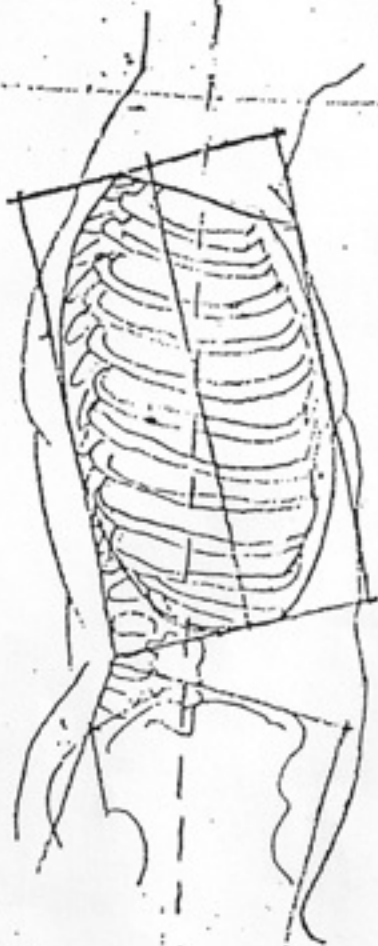

RELATIONSHIP OF CHEST VOLUME TO BODY OUTLINE
AND RIB CAGE

(38)
3-b



PUBIC LEDGE
 1. LEVEL WITH COCCYX

2. M 2" WIDE
 F 2 1/2" WIDE

3. 1" OR MORE HIGH

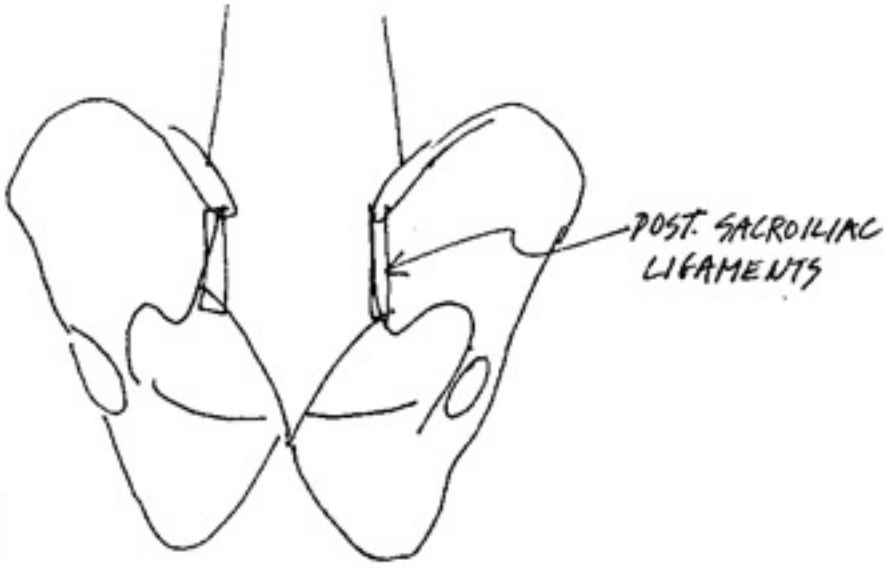

POST. SACROILIAC LIGAMENTS

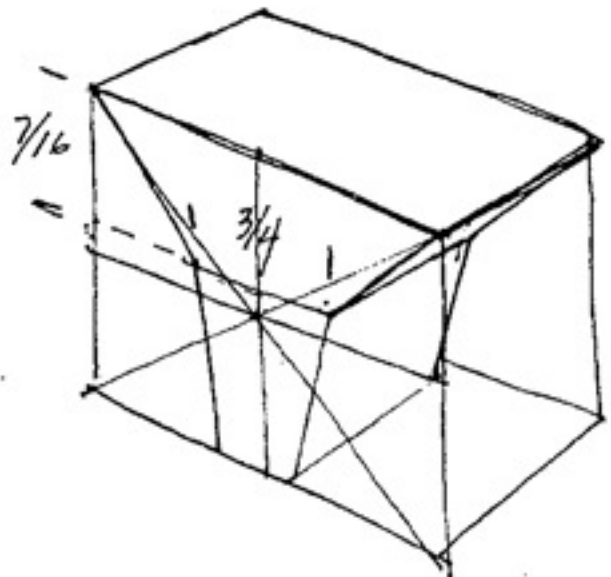
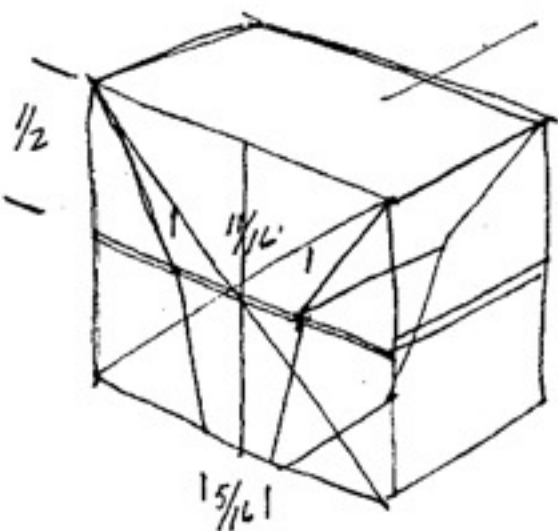
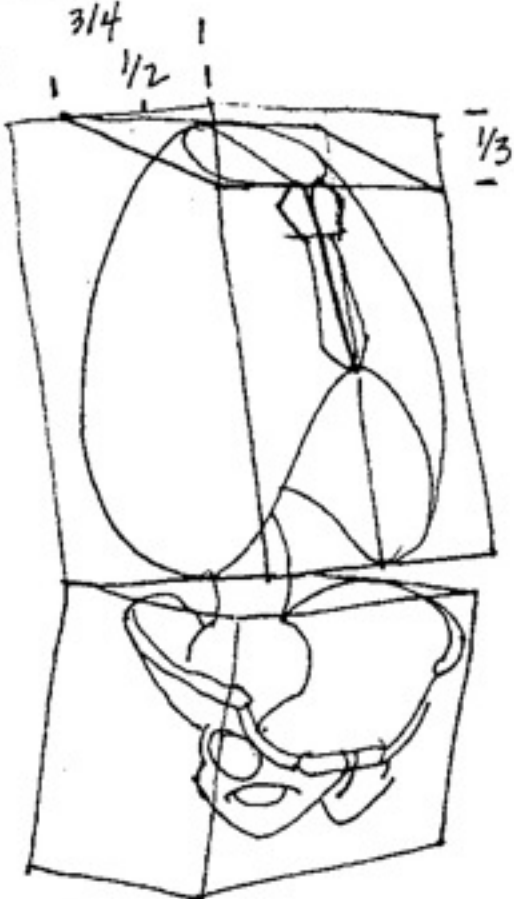

MALE

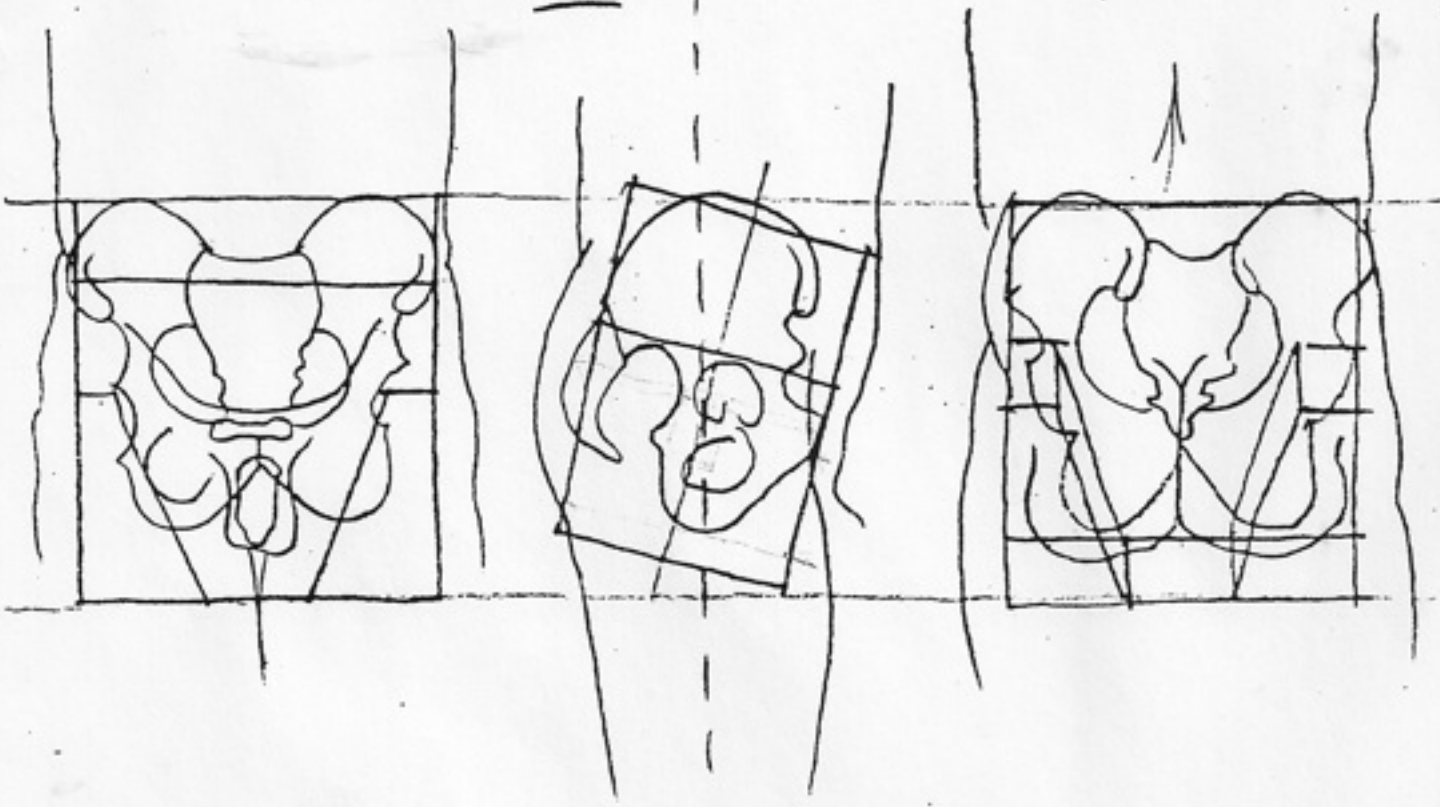

FEMALE

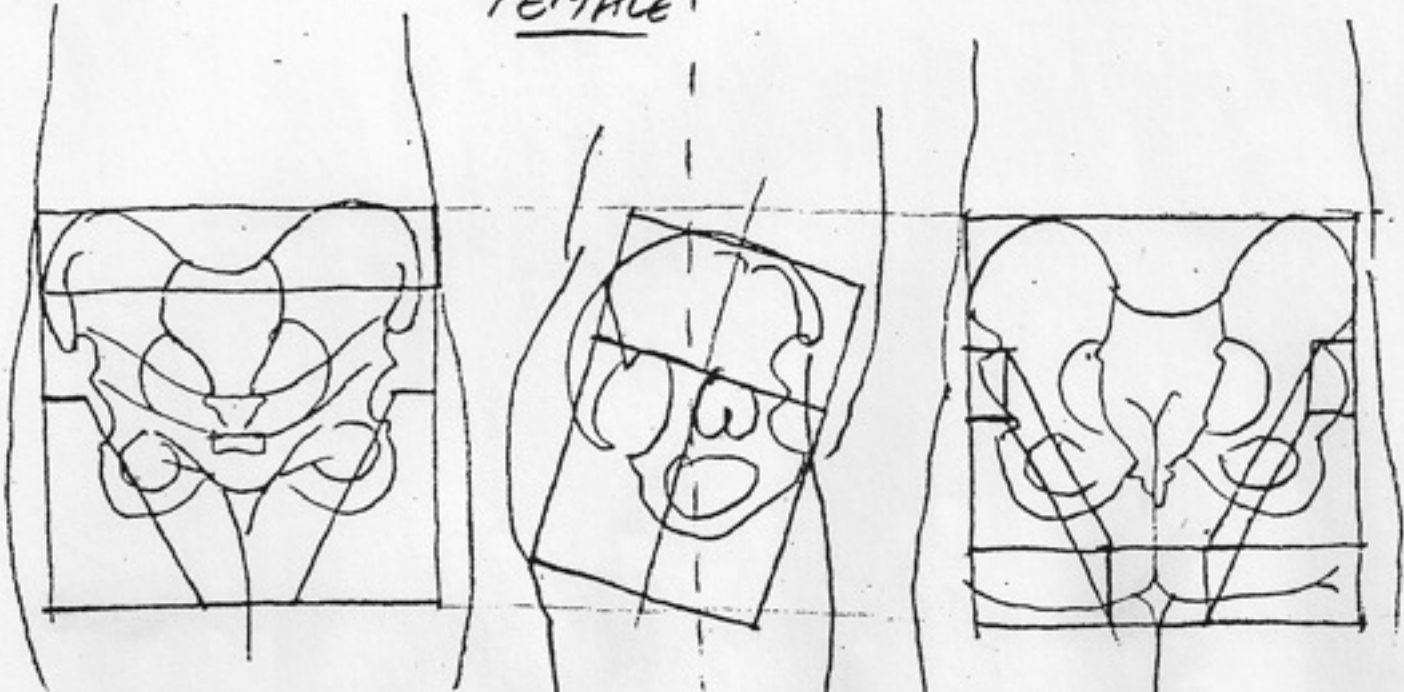

(76)

RELATIONSHIP OF PELVIS VOLUME TO BODY
OUTLINES OF THE LOWER TRUNK & THE
PELVIS