

Caroline Marine Alizée Garreau

BFA Fashion Design

<http://portfolio.newschool.edu/garrc817>

# Jardin des plantes

Black pen, pencil and watercolours on paper.

Project based on observation drawings of plants, animals and bones.

Drawing & Imaging

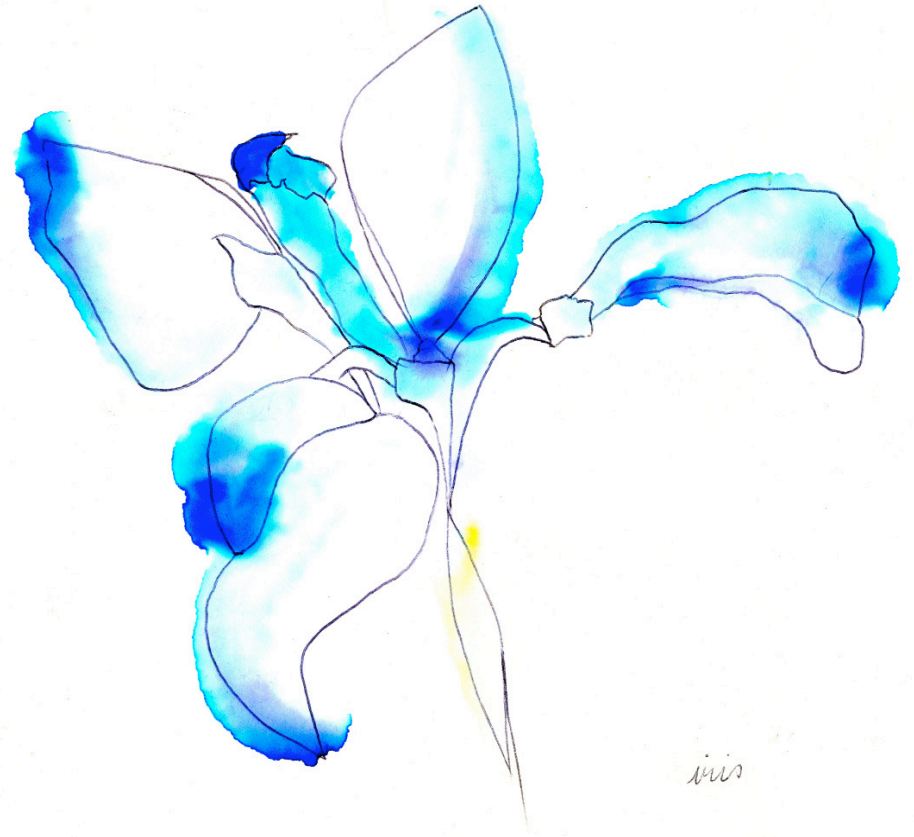

*iris*

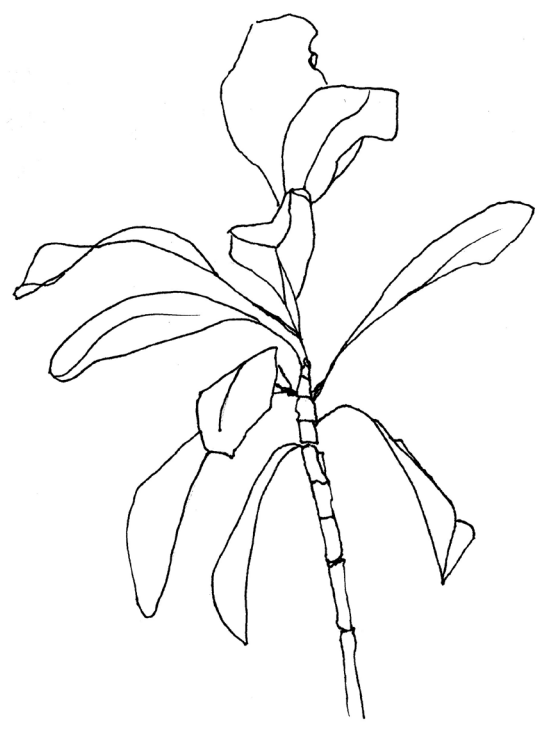
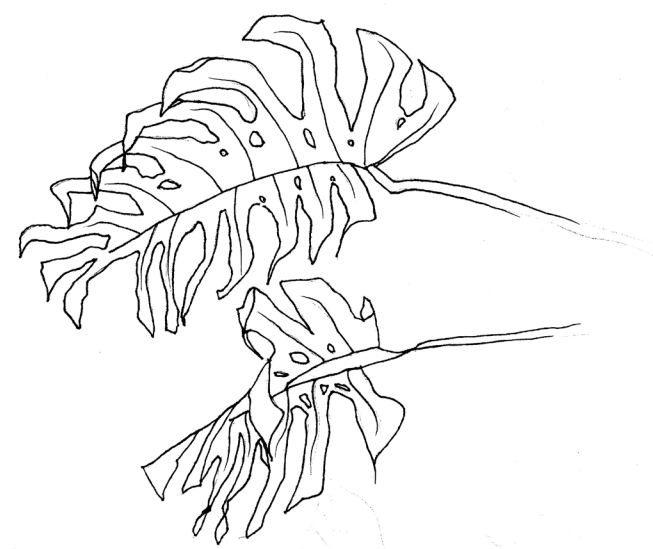
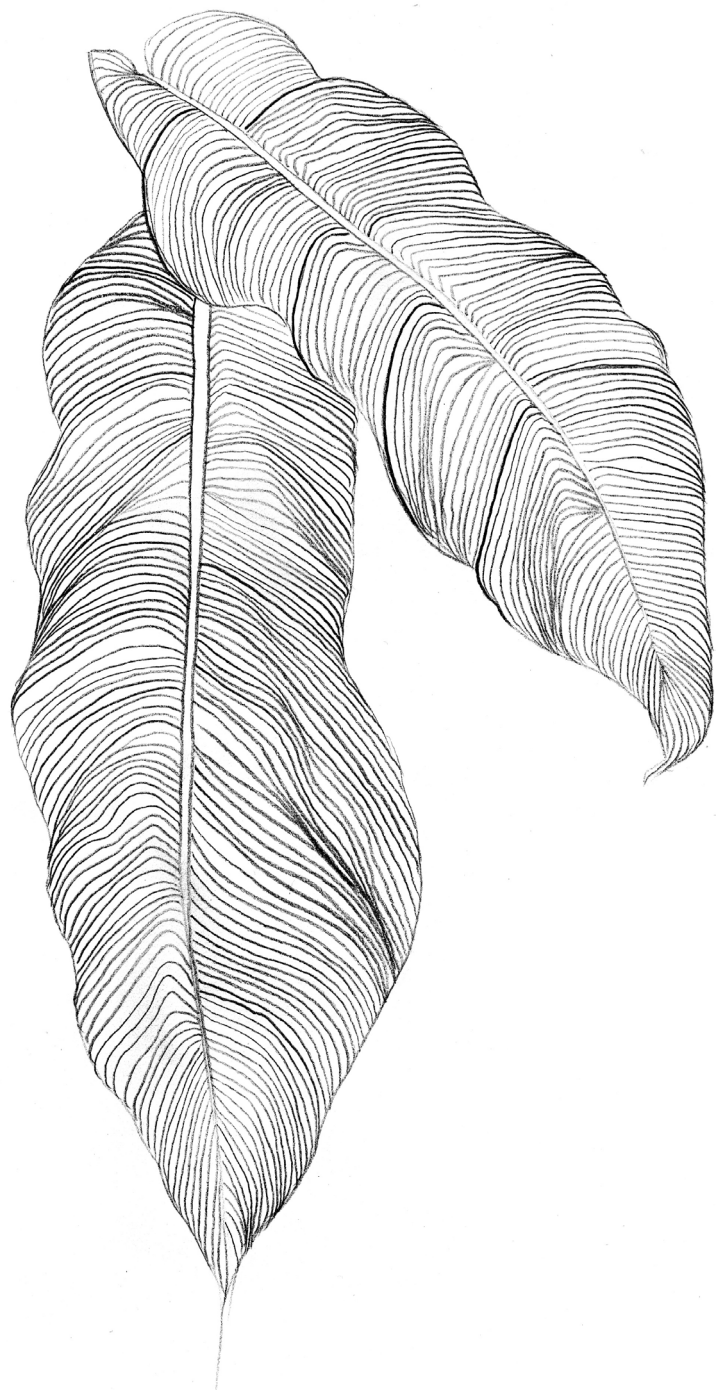

# Figure drawing

Black pen and pencil on paper.

Project based on observation drawings of the body, muscle and bone structure.

Drawing & Imaging





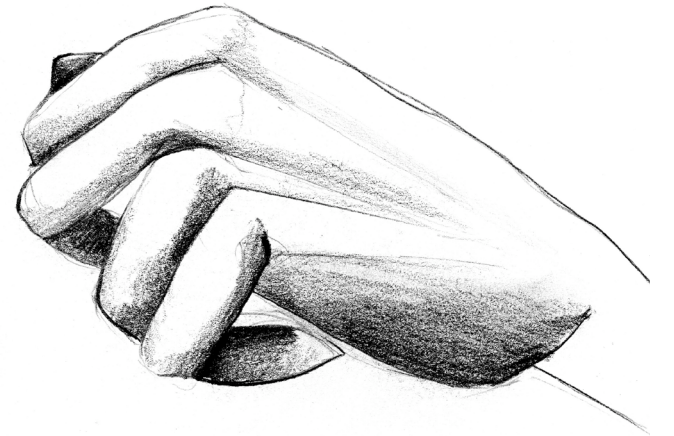
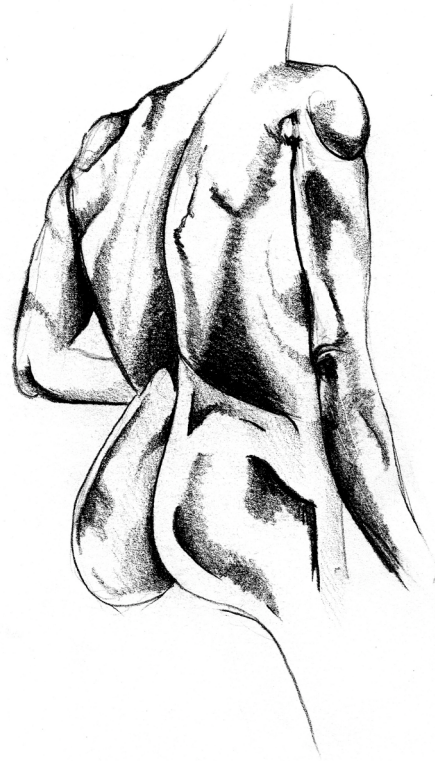
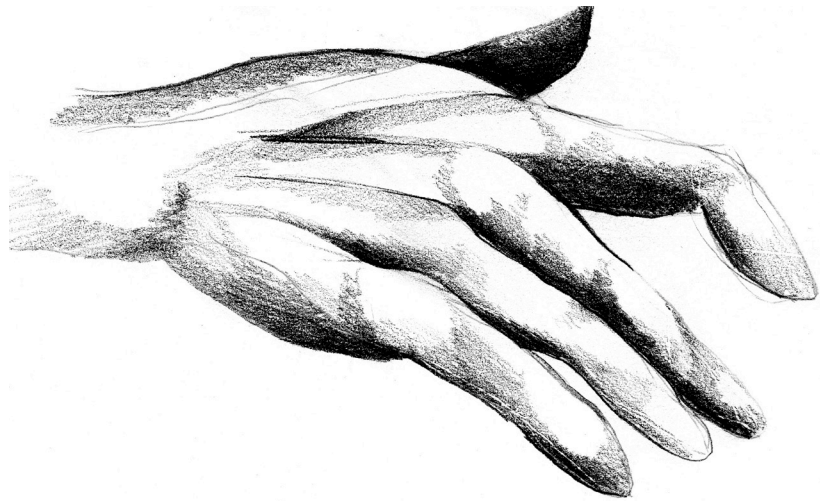

# Textile design

Adobe Illustrator.

Exploration of the various tools found in  
illustrator through the creation of patterns  
and shapes.

Drawing & Imaging

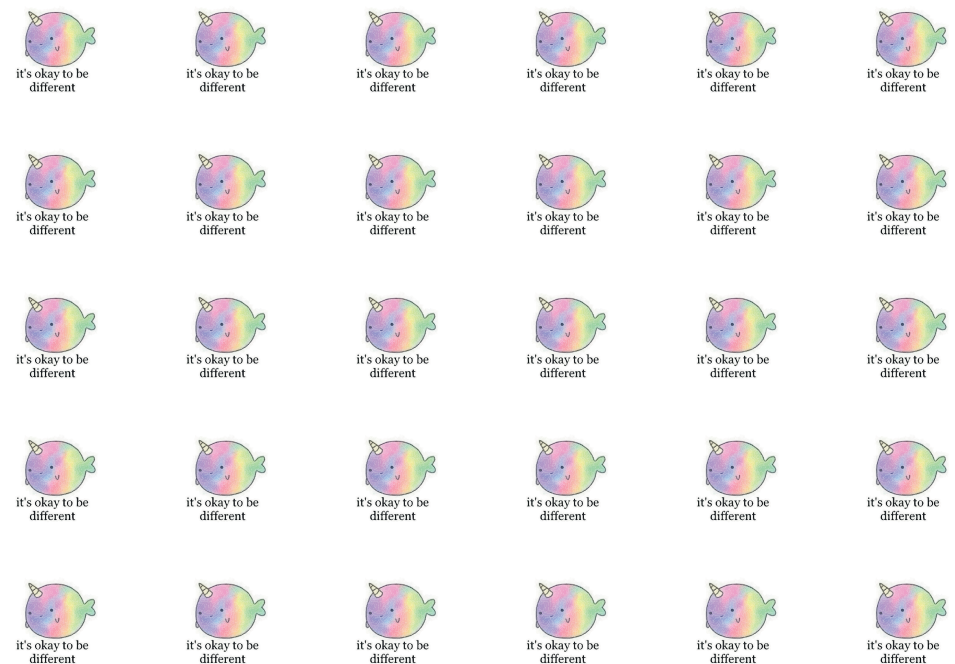
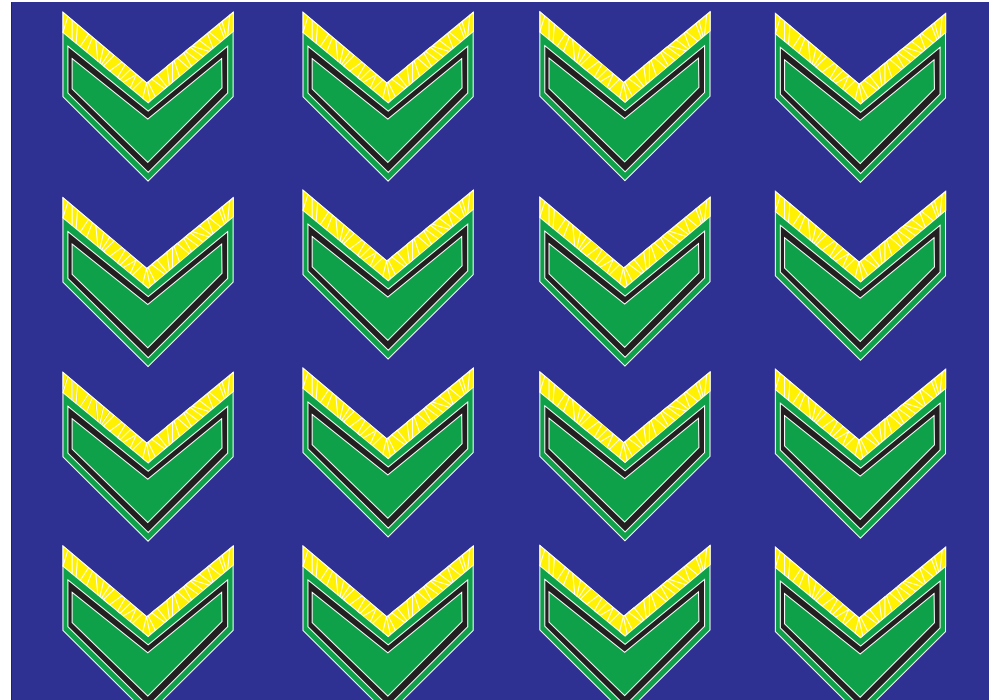

# Imagined landscapes

Adobe Photoshop.

Exploration of the various tools through the construction of unrealistic environments and atmospheres.

Drawing & Imaging





# Sarcastic advertising

Abode Illustrator and Photoshop.

Anylisis of the many techniques used in  
advertising to make our own.

Drawing & Imaging



WINTER IS COMING,  
PROTECT YOURSELF.

durex

# Final project

Mixed media on paper.

Project inspired by topics that are of personal interest to the students and their relating environment

Drawing & Imaging

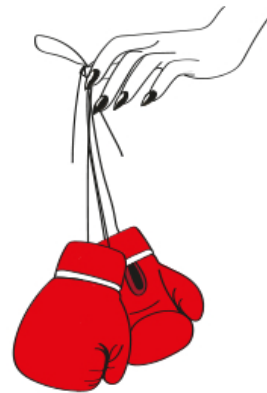
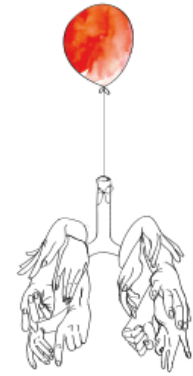
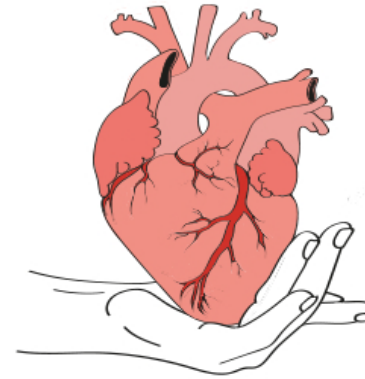

# Dérive

Mixed media on paper.

Inspired by the idea developed by Guy Debord in the 'Theory of the dérive', based on the observation and interaction with the urban context through visual memory.

Integrative Studio 1



# Research



## Eugenia Loli's Interview

~ **When and where were you born?**  
1973, Athenes (Greece)

~ **What have you studied?**  
I studied Computer Programming and database analysis. I lived in Greece and later on in Germany, France and the UK - I now live in the USA.



~ **What made you want to make Art and Collage?**  
After I saw other Pop collagists' work in 2012, on Tumblr, I felt the need to make my own. (Julian Pacau's work was one of her first inspiration)



~ **What is the message you want to illustrate in your work?**  
There are multiple messages, but most of it has to do with a sarcastic look at the human stupidity.

~ **What is your objective when you create those collages?**  
Sometimes it satisfies me. Collage is like Tetris, it feels satisfying when all the pieces come together.



Interview done by email in 2016.

# Process

“The derive has led me to develop a final piece around the 3rd language that I used, which was photography. The photographs taken include a certain symmetry, a vanishing point on the horizon lines and the converging lines the buildings. After they were flipped by accident, the sky created a mirror effect resembling water. Therefore, I wanted to include objects that would be in relation to the water, which would perfectly add up to the originality of the photographs. I also wanted to give the posters a vintage touch by choosing the appropriate images.”

# Display

“The posters were printed on A3 papers. This size was chosen in relation to the old vintage posters that could be found in Paris at the time. Not too large, not too small, this size was the perfect one to be displayed around the city. The aim was not to produce pieces that could be displayed around town rather than on the large panels of the metros, for instance.”



# Remake

Acrylic paint on textiles.  
2 x 2 m.

Piece inspired by the work of Haris Lithos  
and the concept that the  
female body is a form of expression and  
beauty.

Integrative Studio 1

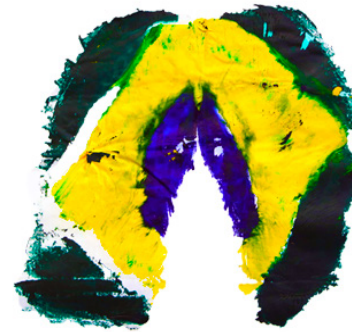

# Research



“Haris Lithos is a young contemporary artist originating from Greece. He studied Psychology and Fine Arts, however in both cases, decided to leave the courses prematurely. Lithos does not acknowledge himself as an artist, ironically, he claims to not be aware of the meaning of the word, but he is rather open-minded about his inspirations on a daily basis.

With sources of inspiration coming from the Pop art movement, Lithos’ art also recalls the work of artists such as Ives Klein, Marcel Duchamp, Shigeo Kubota, Piero Manzoni as well as Georgia O’Keeffe.



In 2005, Lithos created a series of works called ‘Flag Series’, some of which he shared on his personal account on Instagram. Once we were aware of this series, we decided to take this same approach for the remake but with our own flags. Our group is very diverse, we are people from all over, and we decided that it would be more interesting to add ourselves into the project than just remaking it. Besides the subtle change of the different flags and backgrounds, we followed Haris’ works by heart. We painted ourselves and each of us imprinted their own flag into their own canvas.”



# Process

“The way this piece was accomplished was done in a rather simplistic manner. The technique used was the same as the one Haris Lithos uses to produce his body prints. The sheets were laid down on a flat surface, low enough so that we would be able to sit down to create the prints. The acrylic paint was applied directly on the skin using brushes mainly. Once the paint was applied, each and everyone of us then needed to sit on the sheet for the flags to be printed.”

# Display

“The display of the piece was of great debate during the many critics that took place. However, the disposition that turned out the best was to use a single print from each country on a white background after digital manipulation on Photoshop. The plain background gave a better sense of texture to the piece.”

# Artist Statement

“My work is inspired by the environment and the people that are around me. My International surroundings have allowed me to explore issues that many have experienced though, my interest goes towards the varied perspectives on topics that are of personal interest to me. Generating debate and allowing for both positive and negative interpretations are some of my main objectives.

The diversity my art offers can be observed through the mediums used and the sources I get my inspiration from. The discovery of the Dada movement has had a huge influence on the way I make art, not to mention the concept of collage that has allowed me to create pieces and convey ideas that I would not have been able to do without this technique. It creates an overlapping of meanings, shapes and colors, which end up as a unique assemblage. I also spend a lot of time on social medias, where I find inspiration from artists sharing their art and passion for the work they make. More than a research tool, these platforms allow me to follow the work of curators including the Tax collection, the Invisible realm, the Pink Lemonade, Ali Reza and so many more.

Changing the purpose, function or status of objects and individuals is something I love to incorporate in my work. I want to show the double meaning side of Art, a sarcastic look at the life I live and the way I see things through the use of color, humour and digital manipulation. The meaning of colors or objects in some cultures - for instance flowers throughout the world - is something I always incorporate to give a sense of hierarchy of perspectives and interpretations to my art. The visual simplicity of my pieces however hide a long research process and conceptual approaches to the chosen topic. Simple, colourful and effective.”

“**I** ask my mind to make one further effort, to bring back once more the fleeting sensation.”

Marcel Proust  
Volume 1: Swann’s Way: Within a building Grove, p.31  
Integrative Seminar 1

“**T**aste and smell alone, [...] remain poised a long time, like souls, remembering, waiting, hoping, admit the ruins of all the rest.”

Marcel Proust  
Volume 1: Swann’s Way: Within a building Grove, p.32  
Integrative Seminar 1

“Creativity is some sort of mental activity, an insight that occurs inside the heads of some special people.”

Mihaly Cskszentmihalyi  
Creativity, Chapter II - *Where is creativity*, p.23  
Integrative Seminar 1

“We don’t need to assume that the creative person is necessarily different from anyone else. In other words, a personal trait of «creativity» is not what determines whether a person will be creative. What counts is whether the novelty he or she produces is accepted for inclusion in the domain. This may be the result of chance, or being at the right place at the right time.”

Mihaly Cskszentmihalyi  
Creativity, Chapter II - *Where is creativity*, p.28  
Integrative Seminar 1

“My heart started beating as I was hearing about the French Monarchs, who had been decapitated at the exact point where I stood. The significant amount of noise brought by the traffic around the area made me think of the cacophony that surely took place at the time of this tragic event. This prolonged, loud and unpleasant noise in the background, hiding the embarrassment of ignorant souls, I could feel the buildup of tension and rising anger as I walked throughout the site, which made me feel rather uncomfortable at first.”

Writing exercise 2 - Place and memory  
Integrative Seminar 1  
September 2016

# Enhanced object

Black pen.  
A3.

Project base on the complete deconstruction of an object and changing the purpose of this one by making a complete new object.

Space & Materiality

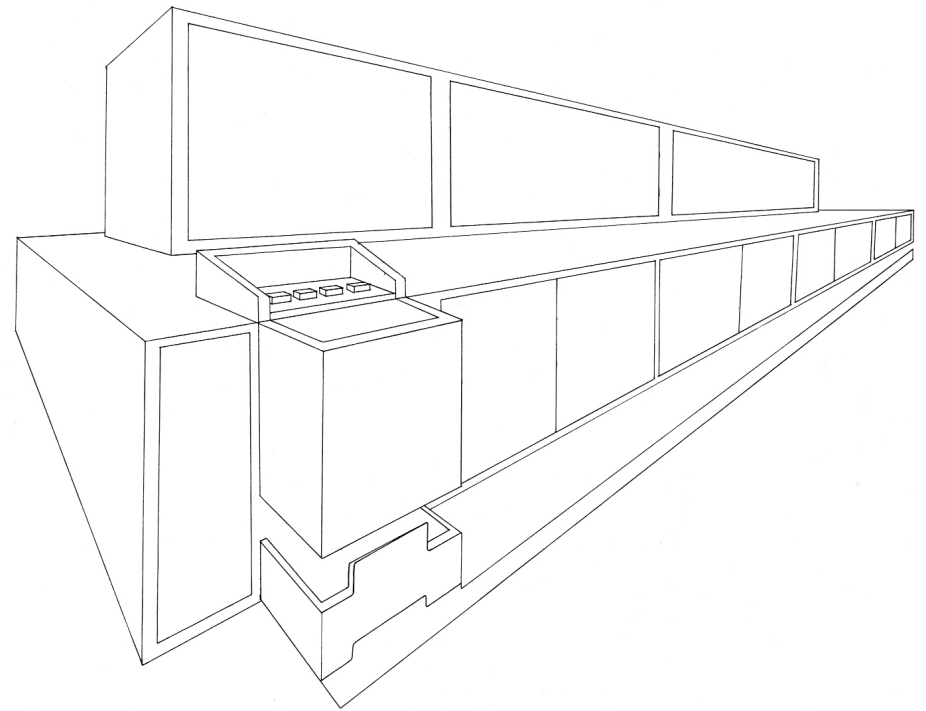



# Process & Research

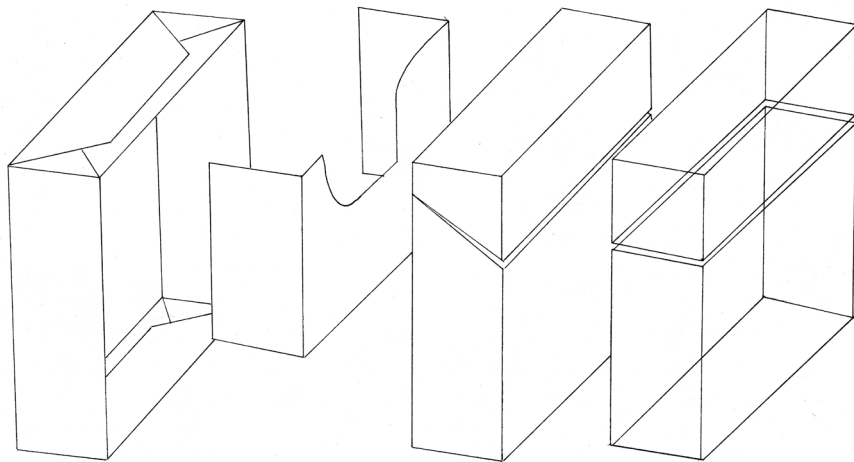

Papier Interieur      Carton Interieur      Carton Extérieur      Papier Interieur

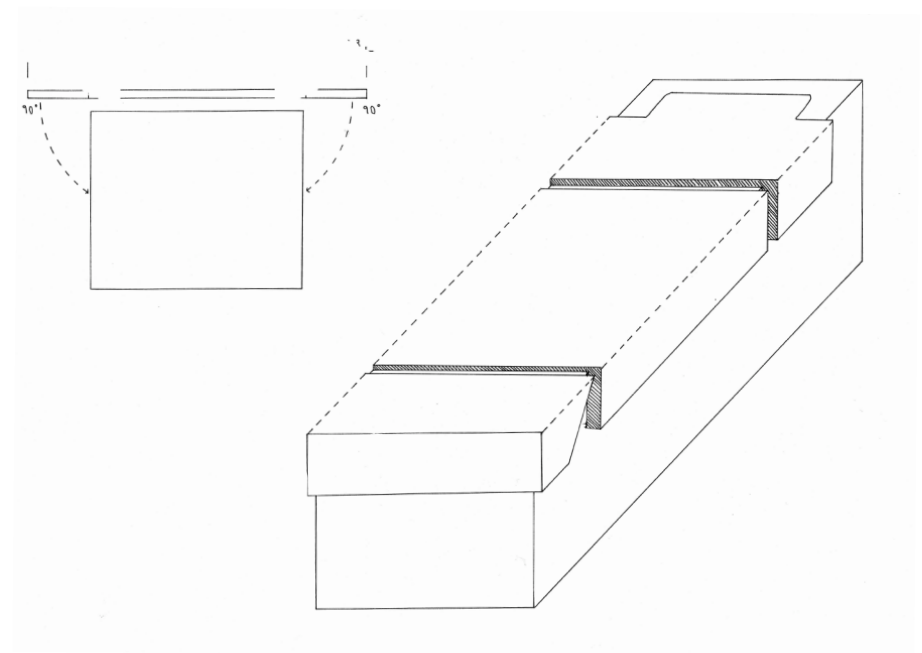
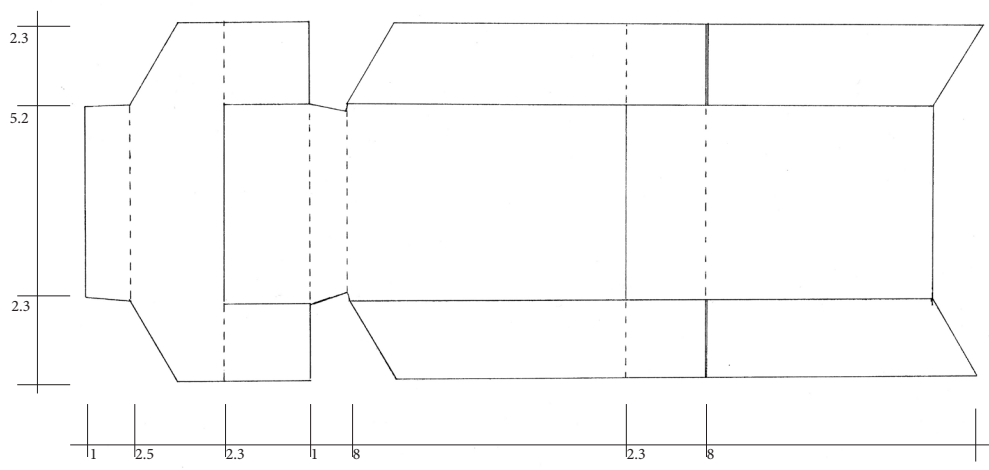
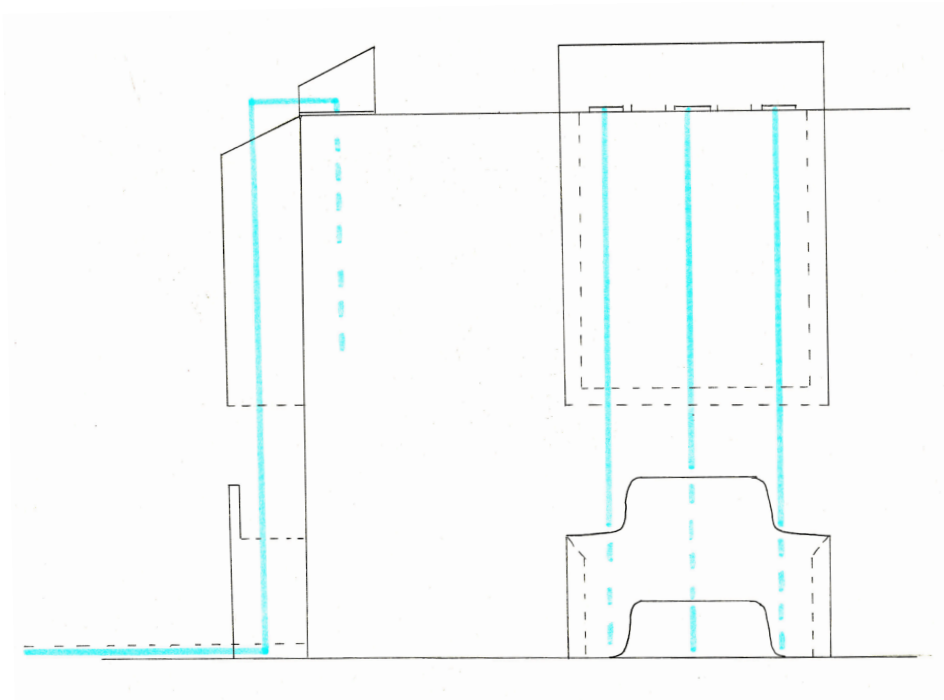

# Enhanced space

Mixed media.

Project base on the complete enhancement of a place by either modifying its aesthetic, function or purpose.

Space & Materiality



# Process & Research

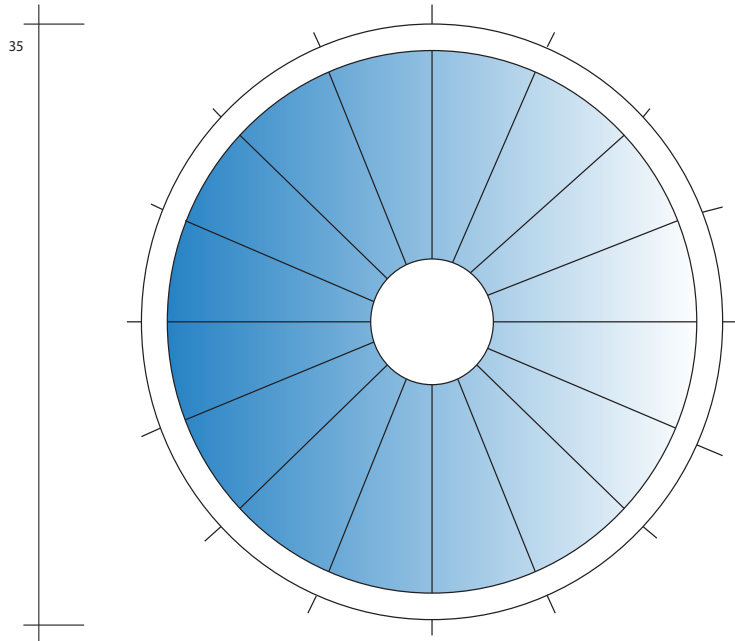

1 : 10  
Top view

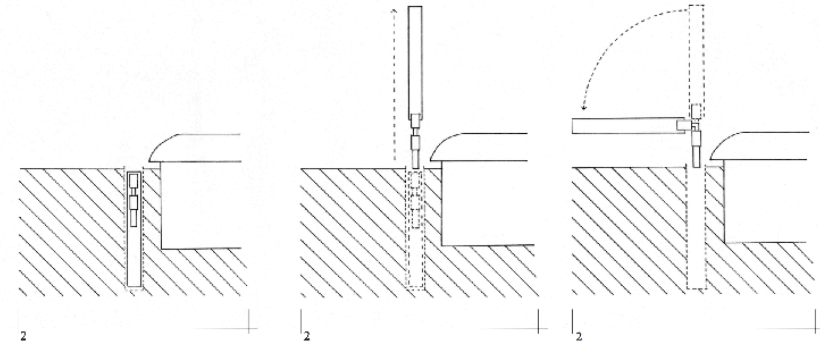

Energy conversion mechanism

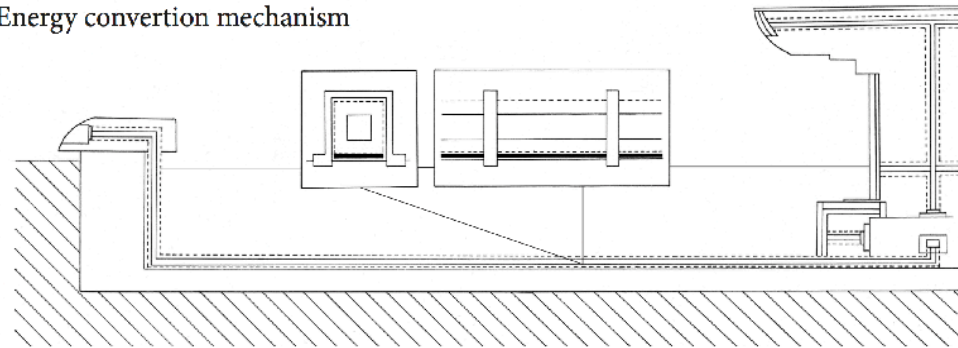

17.5

1 : 100  
Section drawing

## Plinth design

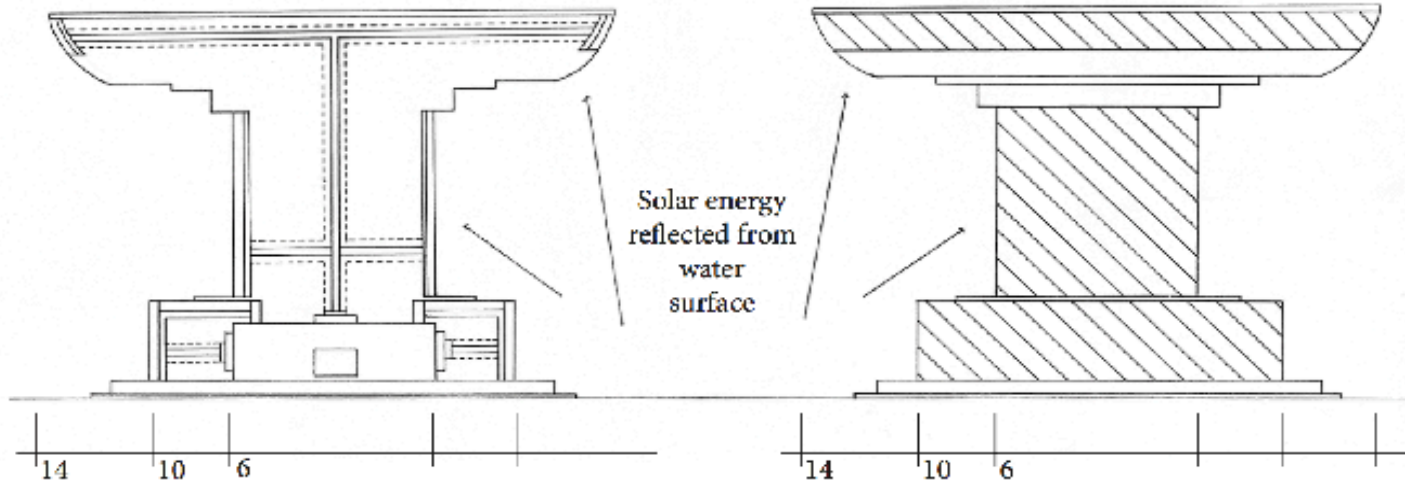

1 : 100  
Section drawing

# Personal learning objectives

## Current strengths

Drawing

Use of Adobe programs

Individual work

Creativity

Use of wide range of media

## Areas of Improvement

Writing about myself

Assessing personal work

Hands on pieces/work

Group projects