

STUDIO & SEMINAR

JESSICA CHAN

LIMITED EDITION: HOSTILE

BONCH

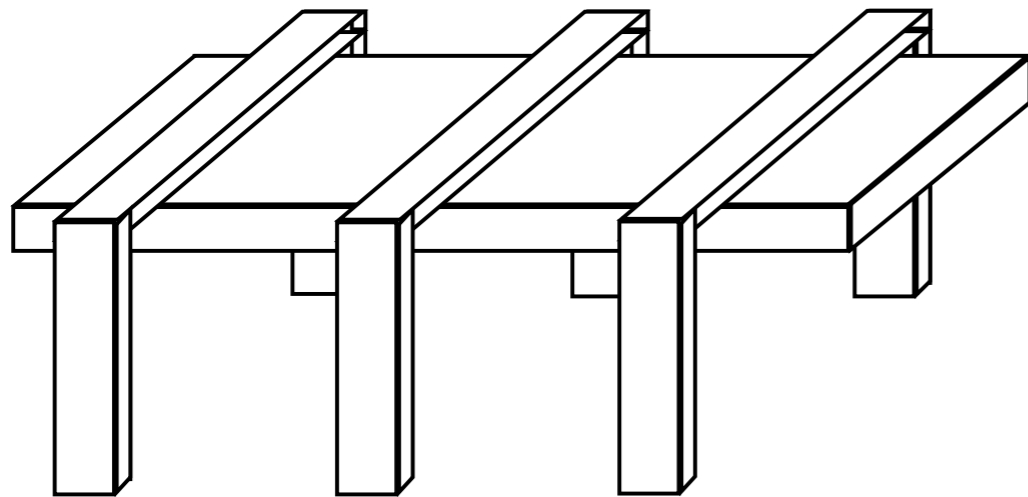

Design and Quality
IKRR of Sweden



THE IDEA

For the many people

The IKRR Concept starts with the idea of providing a range of home furnishing products that are affordable to the many people, not just the few. It is achieved by combining function, quality, design and value - always with sustainability in mind. The IKRR Concept exists in every part of our company, from design, sourcing, packing and distributing through to our business model. Our aim is to help more people live a better life at home.

Bringing the IKRR Concept to life

The IKRR Concept comes to life in many ways: Through our worldwide stores, in the IKRR catalog, via the web and apps, and most importantly in millions of homes around the world.

The limited edition *Hostile Bonch* is currently available in the following countries: Sweden, UK, and USA. Ranging from 10 different colors and 5 different sizes to suit the needs of our loyal customers. Through the *Hostile* series, IKRR aims to explore real world designs taken from major metropolitan cities to create a modern and urban feel for your home.



seminar

inquiry

context/
investigation

interpretation
/argument

connections

reflection

generating potential
research topics:

- list of observations
- finding connections
- what i'm passionate about

DREAMS AND NIGHTMARES

“As a person who experiences dreams and nightmares frequently, I am interested in the interpretation of common dreams/nightmares and the symbolism behind many of them. In addition to this, i'm interested in exploring the cultural attitudes towards dreams and nightmares.

HOSTILE ARCHITECTURE

“After reading about this concept, I began to look at the design and architecture of New York City differently.”

MARIJUANA VS ALCOHOL

For this topic, I would like to conduct an academic discussion on the positive and negative effects of marijuana and alcohol...i'd like to research more on the topic and find out why the legalization of the substance is widely frowned upon in different countries, whereas the usage of alcohol is acceptable.

seminar

inquiry

context/
investigation

interpretation
/argument

connections

reflection

exploring possible topics

- what I was most passionate about

deciding on form, material, color, shape, scale

- mimicking a style
- circumstantial/resources

process in terms of choosing content & translating visually

- struggled because I didn't have any factual research
- depends on what perspective you are looking at
- ethics of hostile architecture

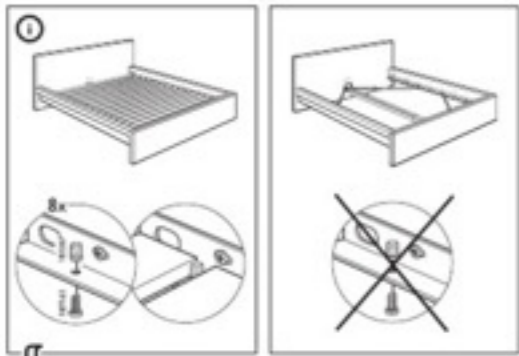

10



© 2014 IKEA of Sweden



MALM

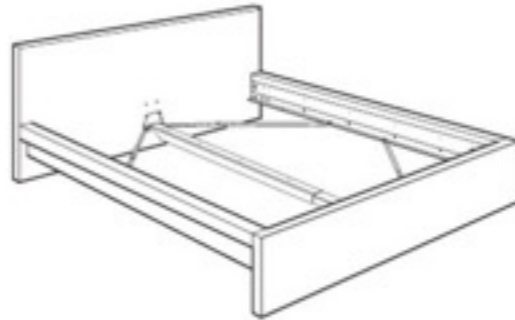

© 2014 IKEA of Sweden

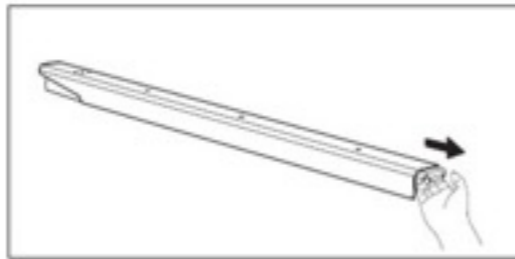

9

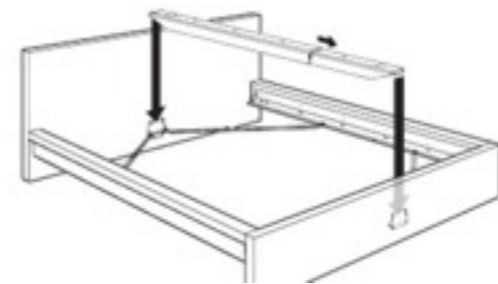

KRUGR

© 2014 IKEA of Sweden

1-2



3-4



5-6



7-8



9-10



EdHarrington.tumblr.com

LIMITED EDITION: HOSTILE

BONCH

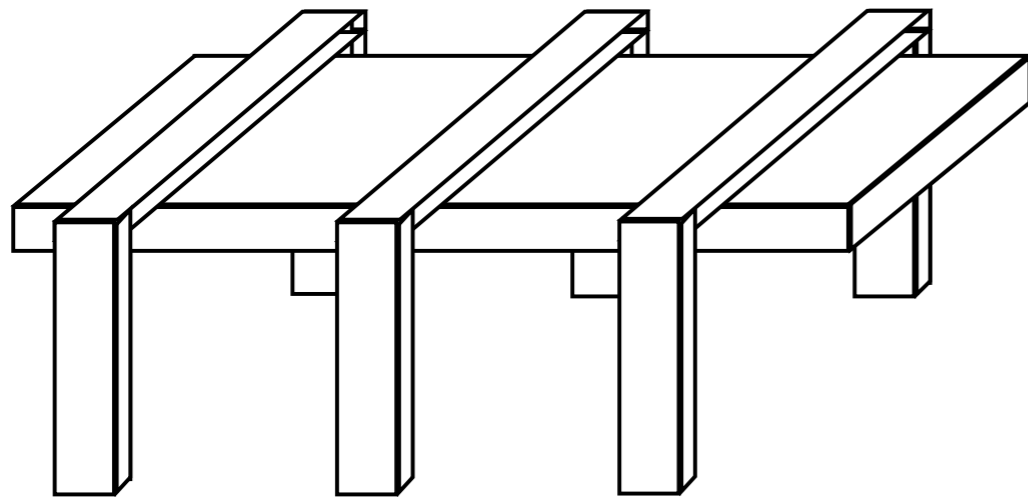

Design and Quality
IKRR of Sweden



THE IDEA

For the many people

The IKRR Concept starts with the idea of providing a range of home furnishing products that are affordable to the many people, not just the few. It is achieved by combining function, quality, design and value - always with sustainability in mind. The IKRR Concept exists in every part of our company, from design, sourcing, packing and distributing through to our business model. Our aim is to help more people live a better life at home.

Bringing the IKRR Concept to life

The IKRR Concept comes to life in many ways: Through our worldwide stores, in the IKRR catalog, via the web and apps, and most importantly in millions of homes around the world.

The limited edition *Hostile Bonch* is currently available in the following countries: Sweden, UK, and USA. Ranging from 10 different colors and 5 different sizes to suit the needs of our loyal customers. Through the *Hostile* series, IKRR aims to explore real world designs taken from major metropolitan cities to create a modern and urban feel for your home.

seminar

inquiry

context/
investigation

interpretation
/argument

connections

reflection

“Doing reseatch is not like strolling along an easy, well marked path to a familiar destination; it’s more like zigzagging up and down a rocky hill through overgrown woods.” - craft of research (30)

- difficulties in finding, investigating, and assessing sources
- challenges encountered in studio project

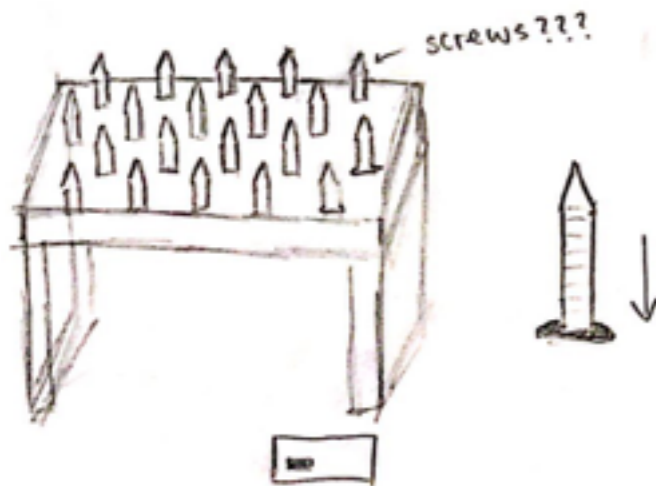

BRIDGE4 :
Initial sketches & ideas

For my project . I would like to design different pieces of furniture that are only susceptible for use when money is being offered. This project reflects the overall concept of my topic "Hostile Architecture" where people of power design objects and spaces that discriminate against certain groups in society, especially the lower class , while favoring the privileged.

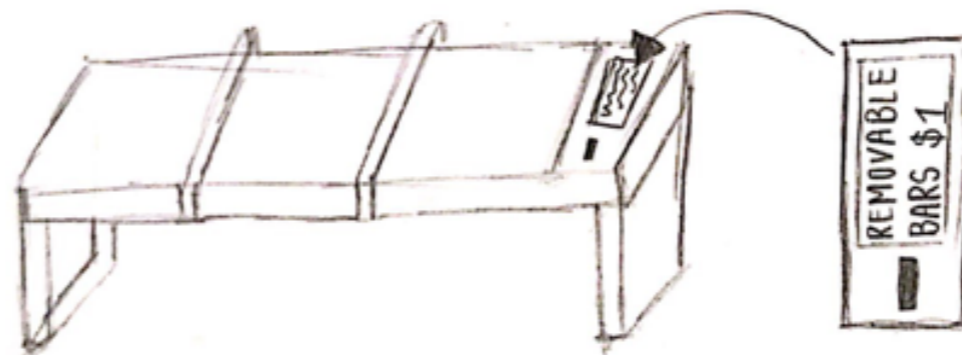

seminar

inquiry

context/
investigation

interpretation
/argument

connections

reflection

- arriving at a thesis statement

There is a type of design called Hostile Architecture which purposely inconveniences, excludes, and marginalizes individuals in public spaces. Despite the defensible reasons for the use of Hostile Architecture, a study of its affects of the use in public space indicates the problematic nature of these design choices.

- storyboarding and outlining
 - writing about examples of hostile architecture around the city (jones beach, MTA, public parks) —-> who and how these designs affect others
- determining ideas for studio

“Even so, once you have a question that holds your interest, you must pose a tougher one about it: So what?” - craft of research (43)

seminar & studio

inquiry

context/
investigation

interpretation
/argument

connections

reflection

what were the ***easiest*** and ***most rewarding*** aspects of the research process & creating the projects?

- laser cutting & circuit making
- changing the way I look at the environments around us
- learning a lot about the process of writing a paper

which were the ***most difficult*** aspects?

- finding great sources
- writers block
- unable to create what I had originally imagined
- resources