

Proportion









Subcutaneous Landmarks on the Human Body

- Parietal (peaks of)
- Pit of neck (intersection of clavicle and top of sternum)
- 7th Cervical Vertebrae
- Acromion Process
- Xiphoid Process
- Nipples (variable)

- Navel (variable)
- ASIS (anterior superior iliac spine)
- Great Trochanter
- Pubis
- Sacral Triangle
- Plane of the knee
- Inner malleolus
- Ground plane
- Calcaneous

Proportion and 7.5 Canon

THE AVERAGE PROPORTIONS IN THE ADULT MALE FIGURE.

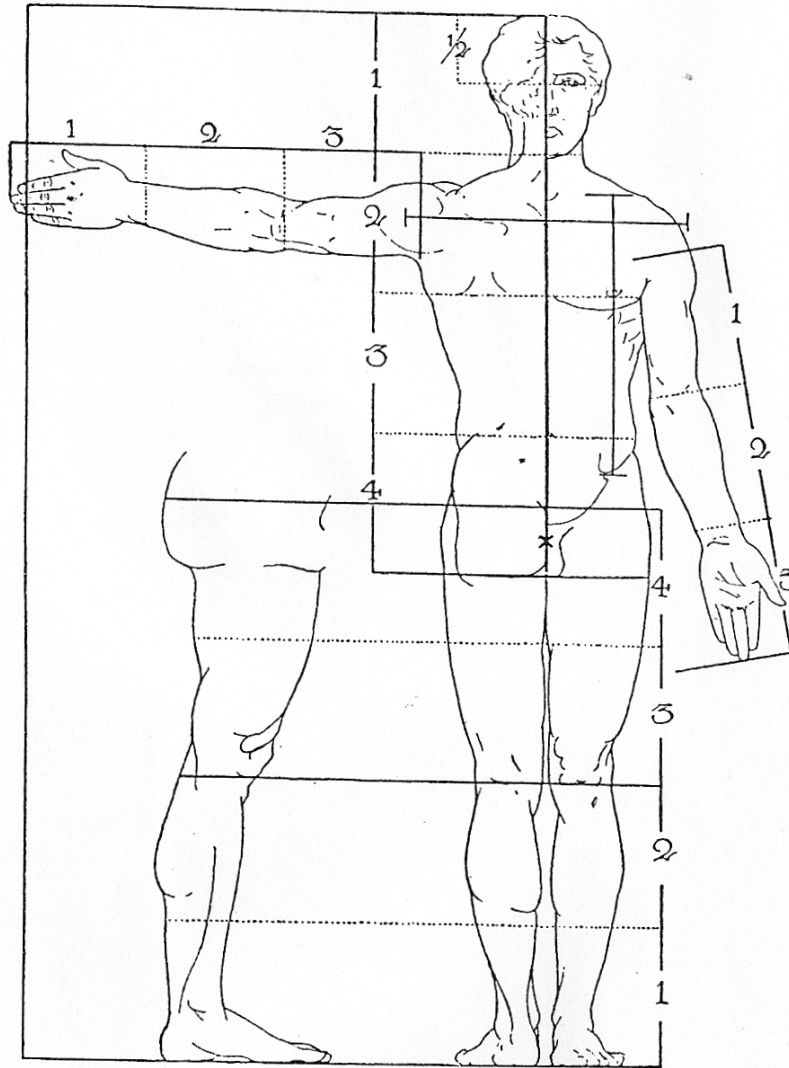

The divisions indicate head-lengths. X marks the middle of the body. (From Richer.)

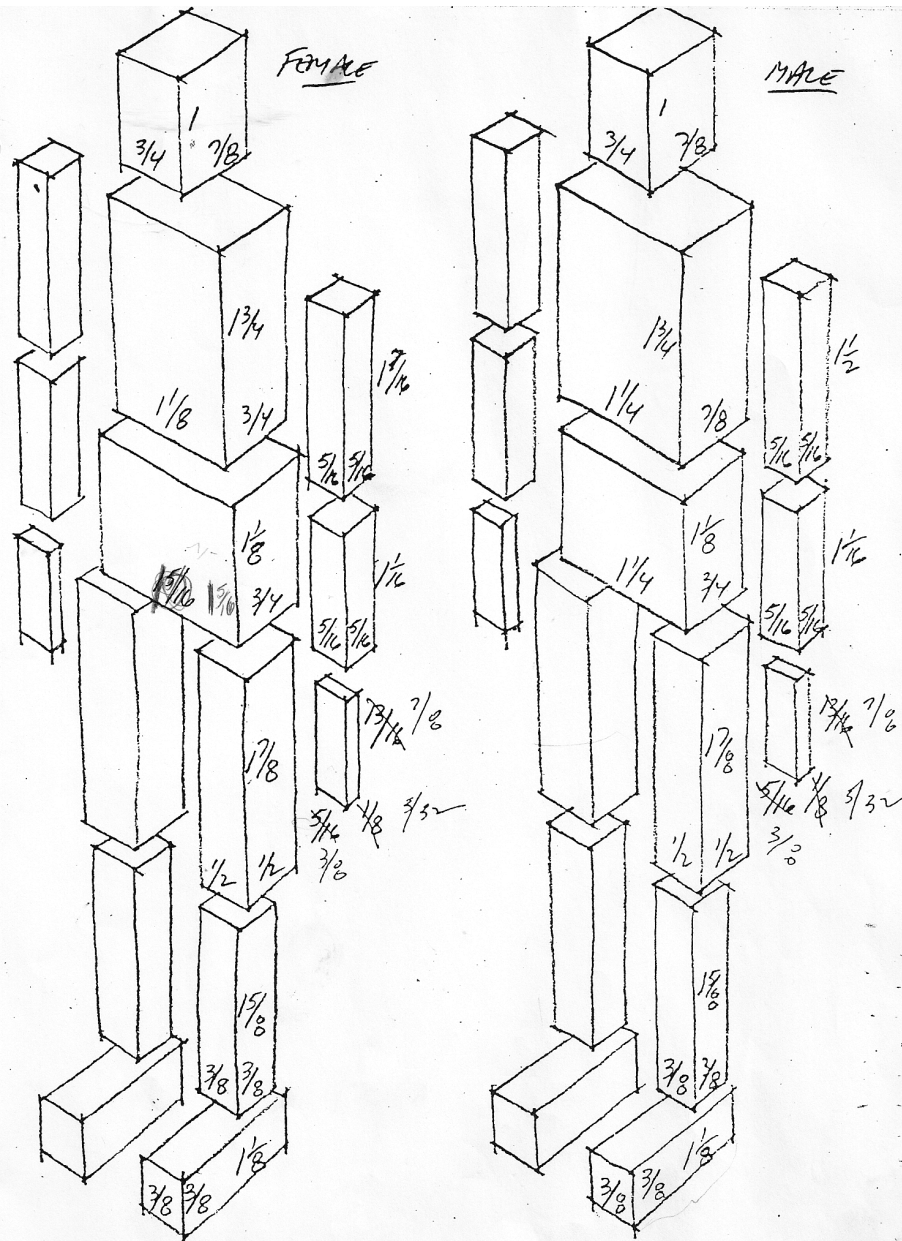

6) PROPORTIONS OF THE FIFTEEN BASIC RECTANGULAR VOLUMES



PUBIC LEDGE
1. LEVEL WITH COCCYX

2. M 2" WIDE
F 2 1/2" WIDE

3. 1" OR MORE HIGH

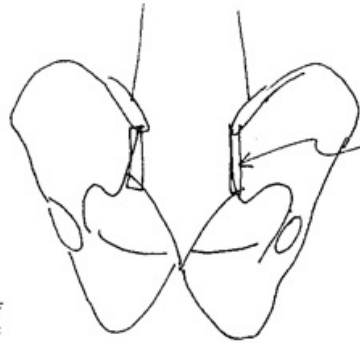

POST. SACROILIAC LIGAMENTS

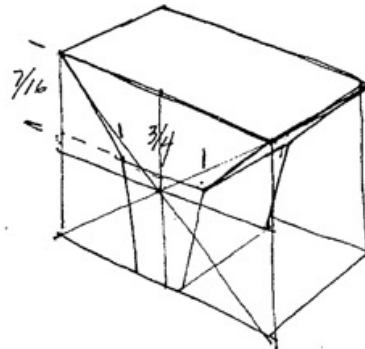
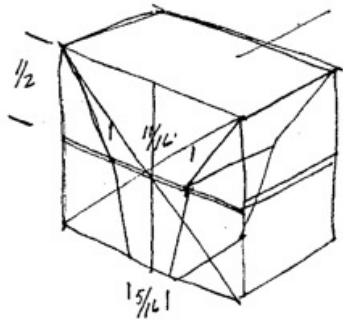
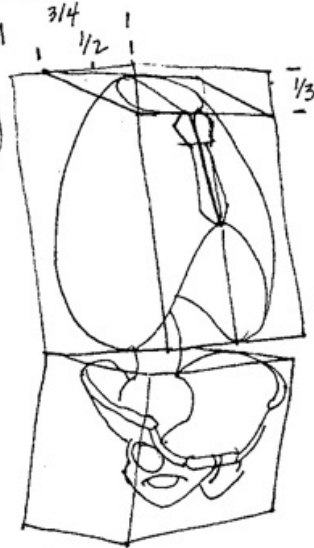

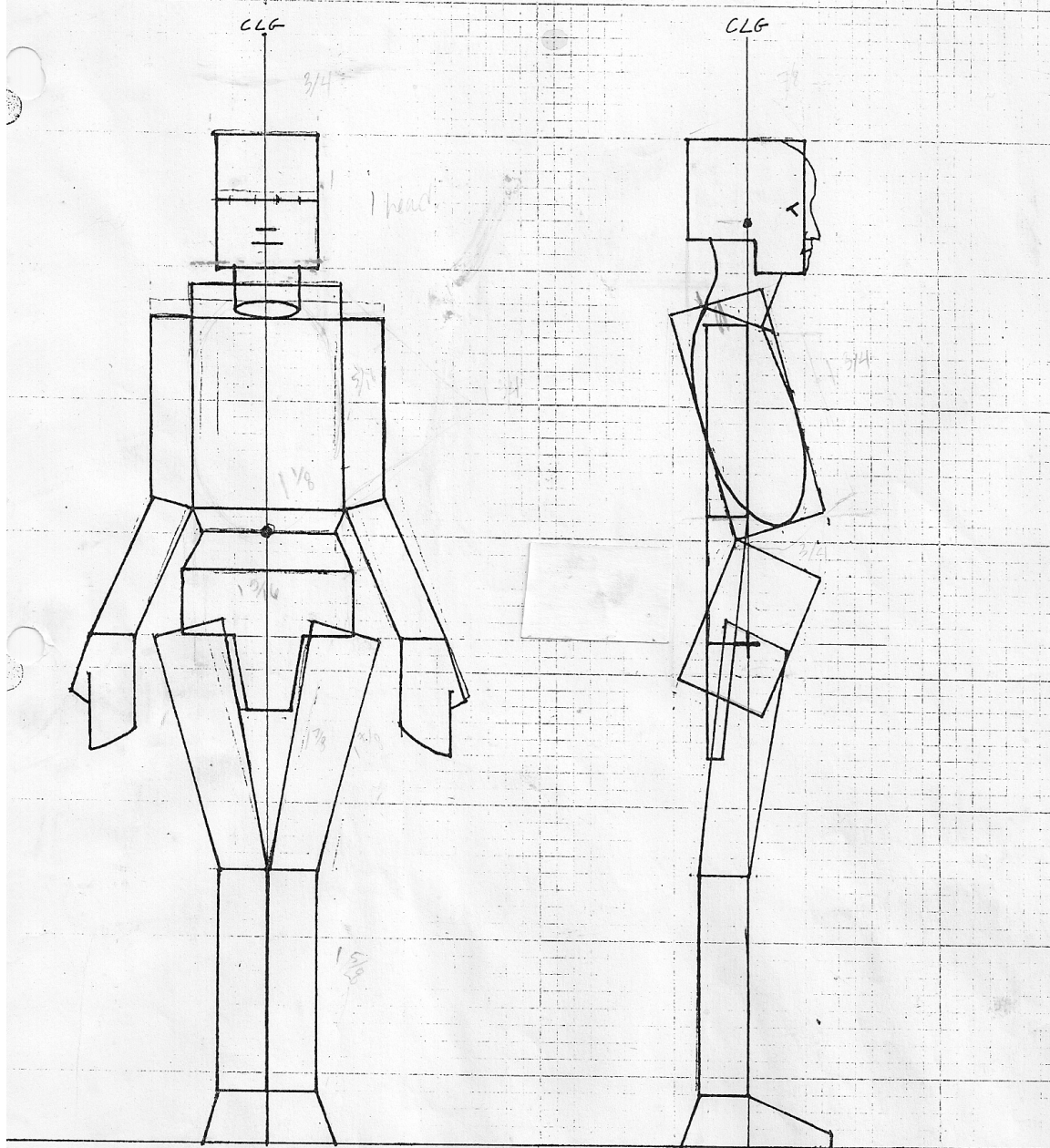

$1/4$ $1/3$

FEMALE

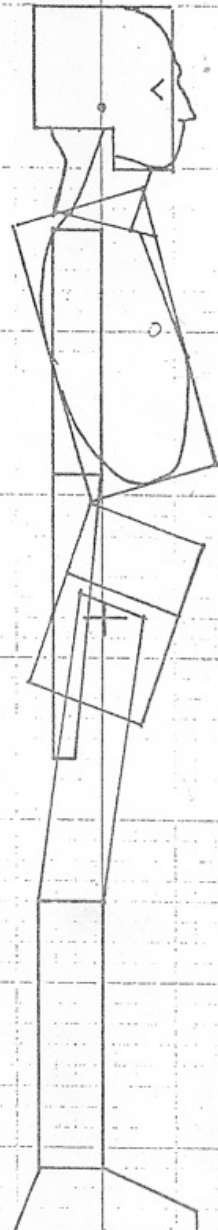
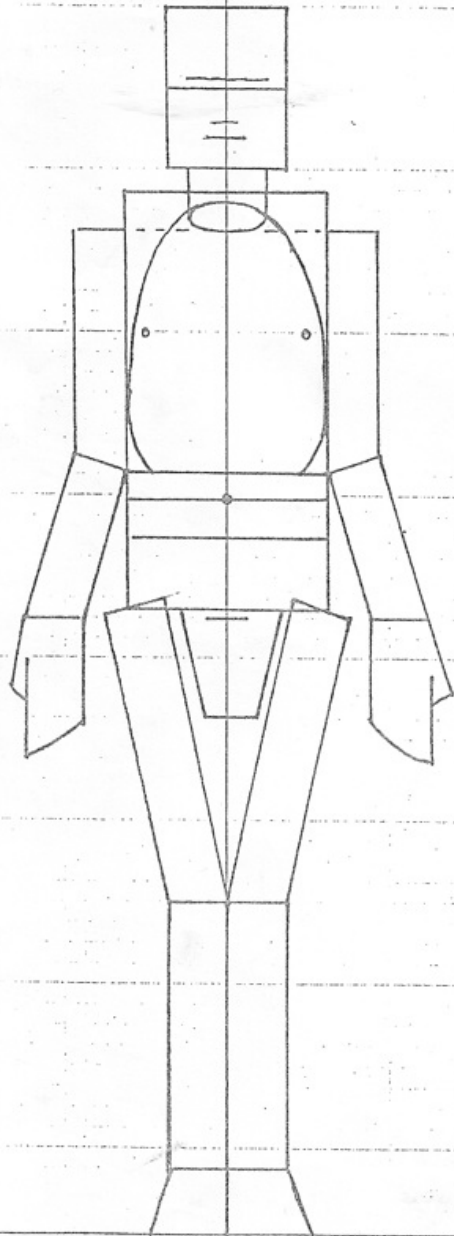

MALE.

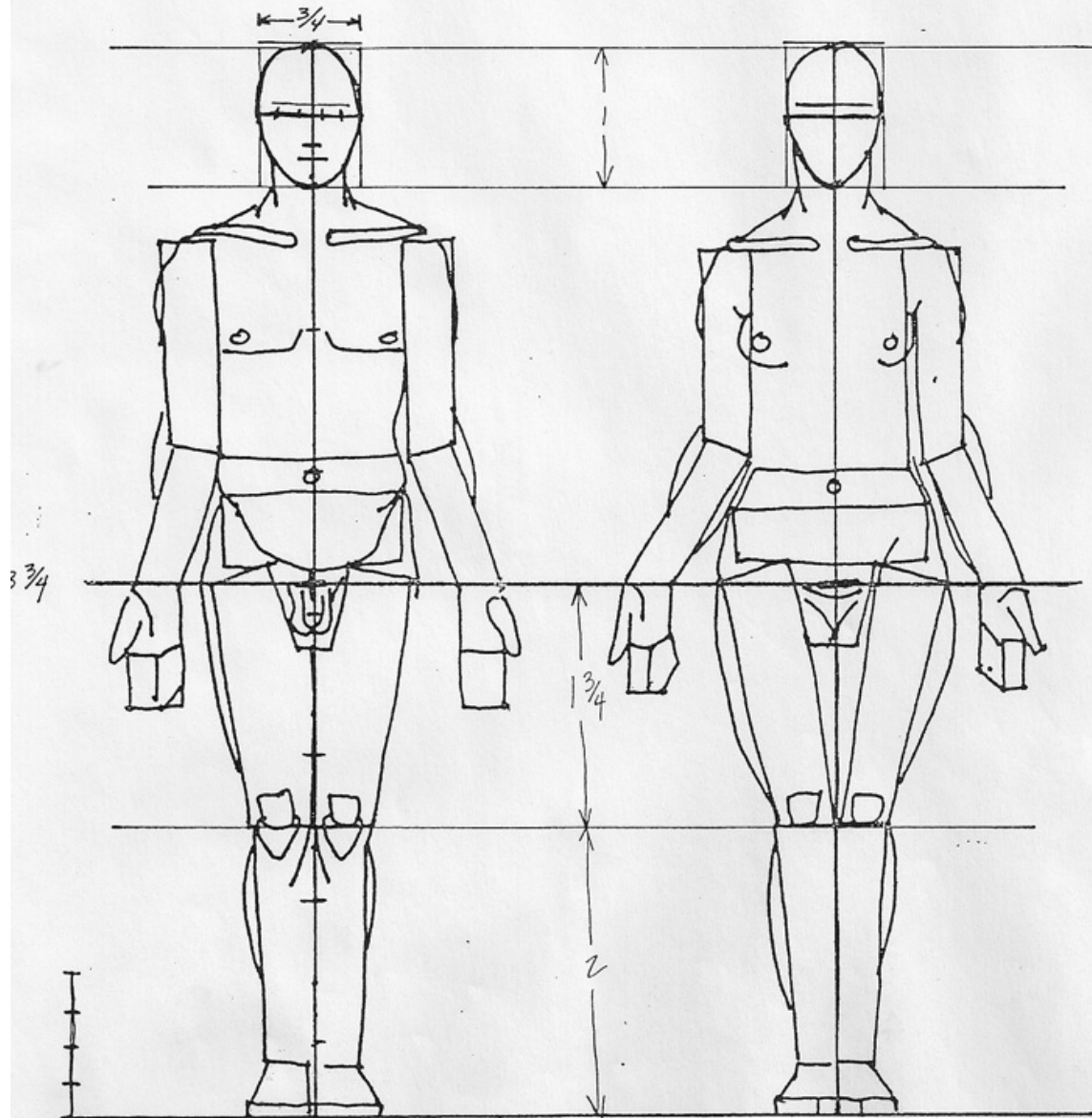

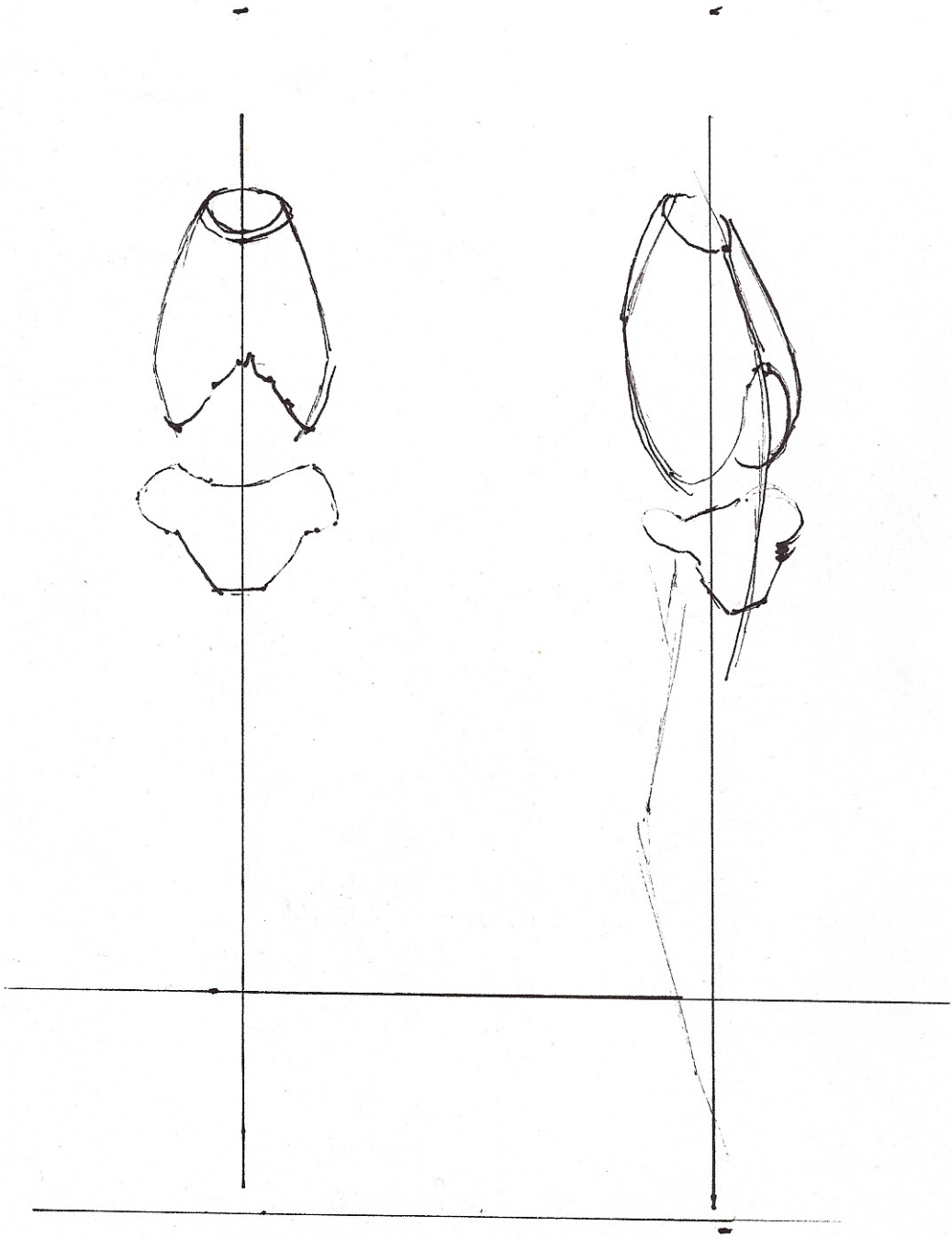

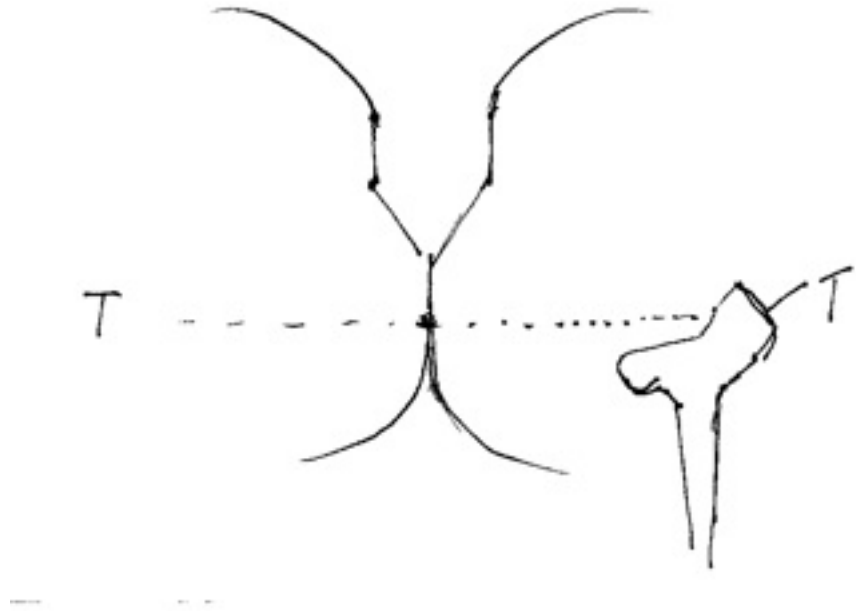

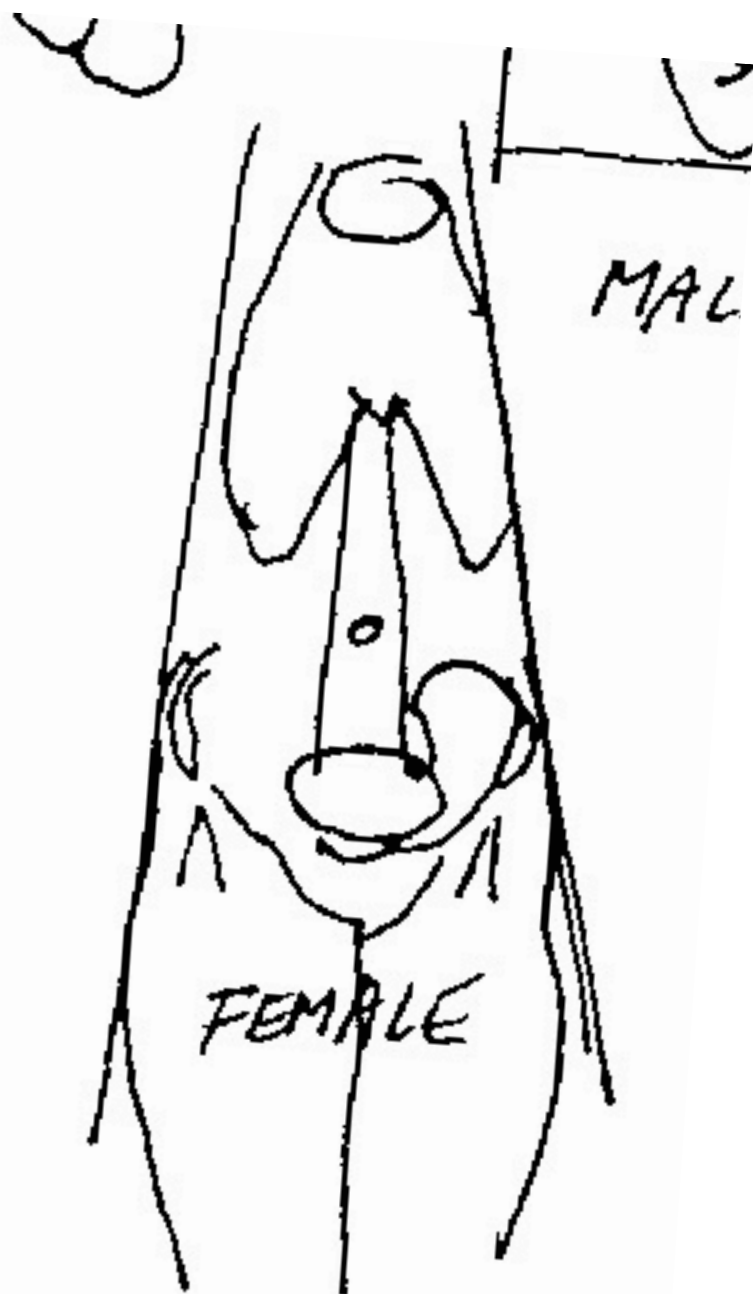





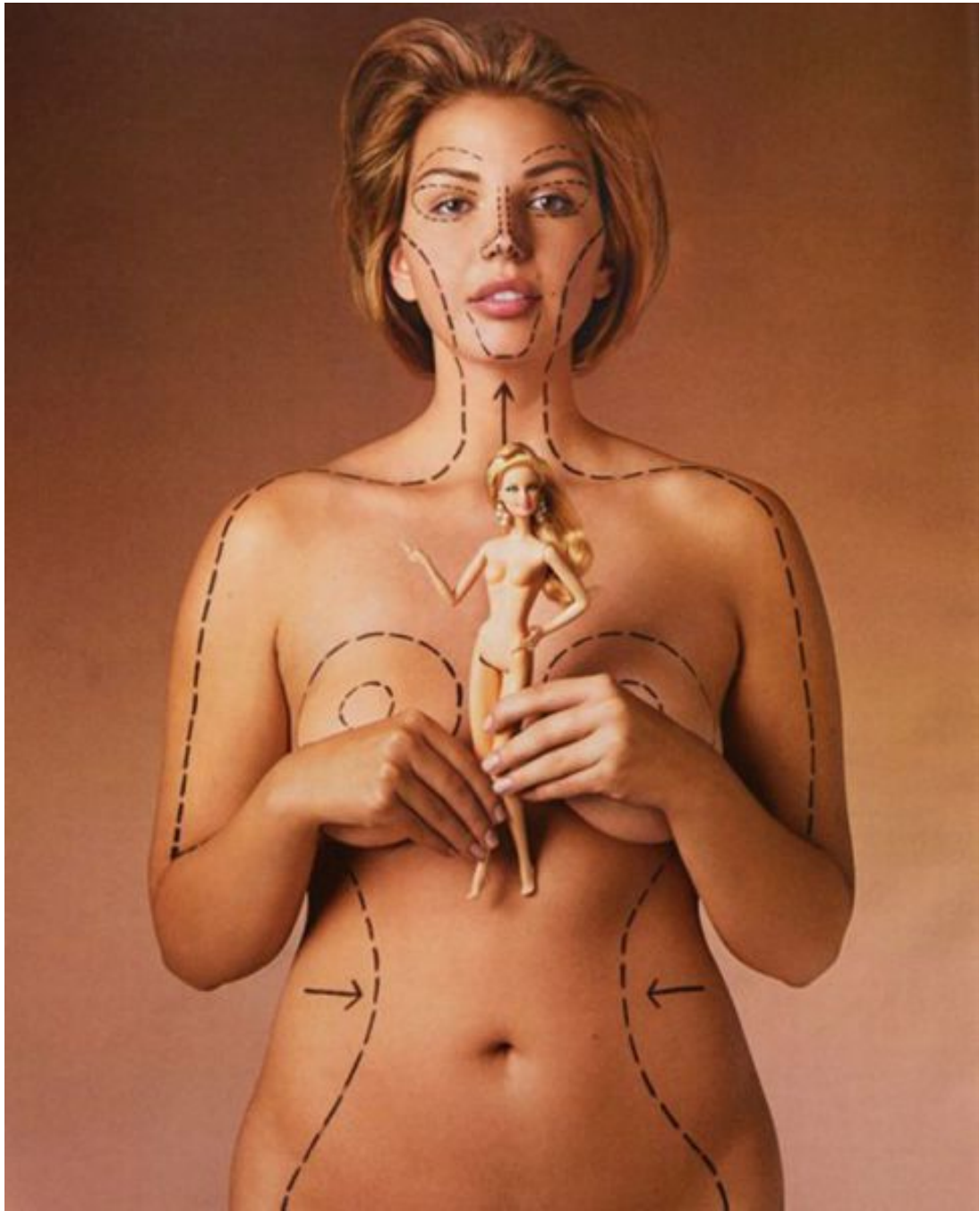



Barbie
(not to scale)



Libby



Libby, 5ft 6in
tall, with
Barbie's
proportions

IDEAL PROPORTION AT VARIOUS AGES

