

IMMINESCENCE

TWILIGHT SKY

MISSION STATEMENT

BY: RACHEL KIM

IMMINESCENCE IS A COLLECTION BASED ON EMOTIONS AND SENSES. THIS JEWELRY LINE IS INSPIRED BY THE TRANSITIONAL PHASES OF NATURE THAT UNITE PEOPLE TOGETHER THROUGH THE SHARED EXPERIENCES. IT CREATES PERSONAL CONNECTIONS BETWEEN THE USER AND PRODUCTS TO CREATE AND EVOKE INTIMATE, INDIVIDUAL EXPERIENCES.

TABLE OF CONTENTS

3
4
6
8
10
13
29
40
42

MISSION STATEMENT

TITLE PAGE

TIME LAPSE PERSONAL REFLECTION

TIME LAPSE ETHNOGRAPHIC RESEARCH

MOOD BOARD

MATERIAL RESEARCH

SKETCHES | COLLECTION

INTERIOR

PDS/CHECKLIST

REFLECTION

ABOUT

TIME-LAPSE

OF URBAN

LANDSCAPE

A STUDY OF IMAGERY OF DIFFERENT

LIGHTS AND TIMES OF DAY

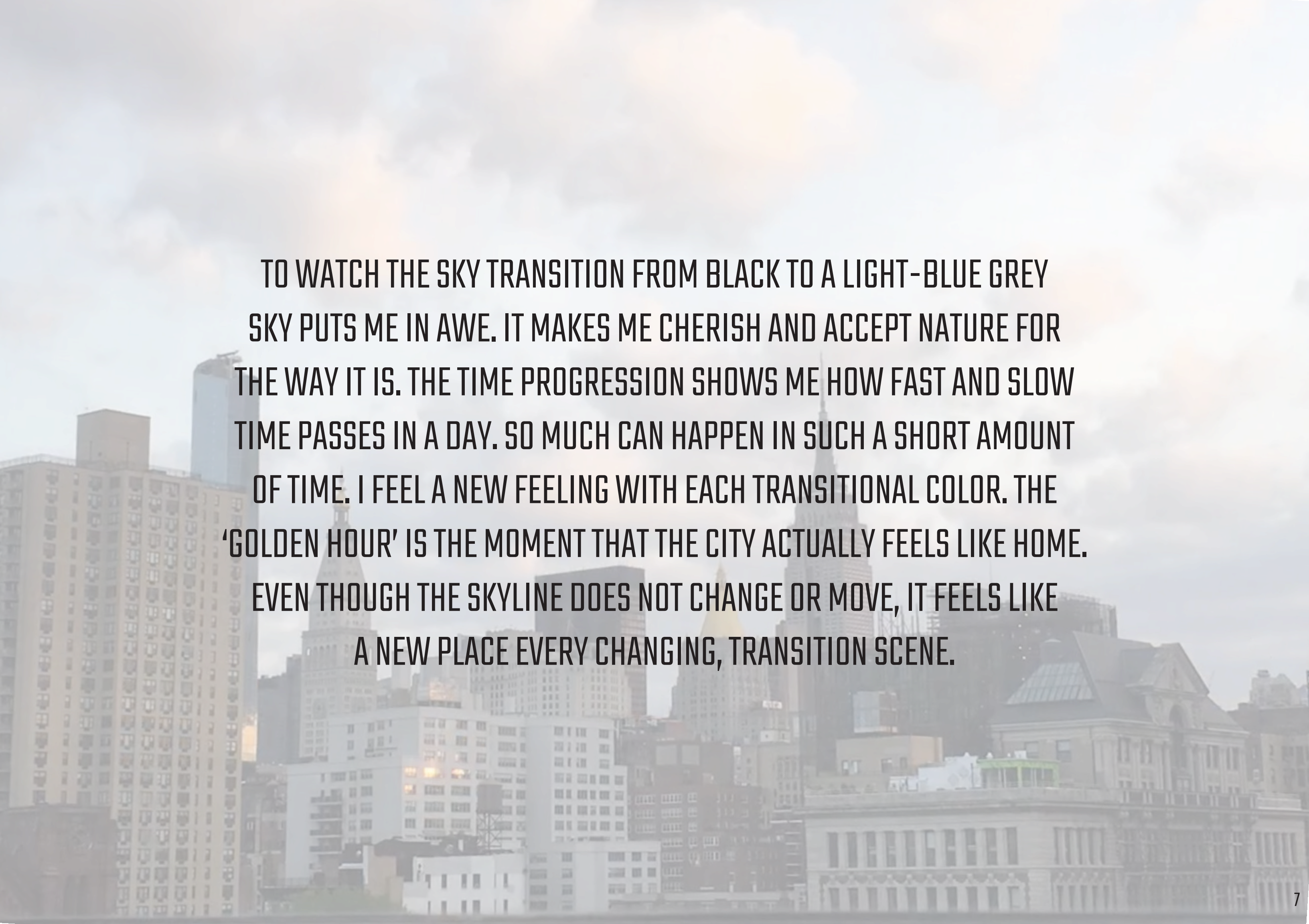

TO WATCH THE SKY TRANSITION FROM BLACK TO A LIGHT-BLUE GREY SKY PUTS ME IN AWE. IT MAKES ME CHERISH AND ACCEPT NATURE FOR THE WAY IT IS. THE TIME PROGRESSION SHOWS ME HOW FAST AND SLOW TIME PASSES IN A DAY. SO MUCH CAN HAPPEN IN SUCH A SHORT AMOUNT OF TIME. I FEEL A NEW FEELING WITH EACH TRANSITIONAL COLOR. THE 'GOLDEN HOUR' IS THE MOMENT THAT THE CITY ACTUALLY FEELS LIKE HOME. EVEN THOUGH THE SKYLINE DOES NOT CHANGE OR MOVE, IT FEELS LIKE A NEW PLACE EVERY CHANGING, TRANSITION SCENE.

TIME-LAPSE OF NEW YORK SKYLINE FROM 5 AM - 8:30 AM



<https://www.youtube.com/watch?v=aMt6Fw07ZJI>

MOOD AND EMOTIONS OF DIFFERENT STAGES OF LIGHT

ISOLATION

CALM

AFTERTHOUGHT

DARK + COLD

START OF A DAY

'EARLY BIRD CATCHES THE WORM'



BUSY + LOTS OF ENERGY
COLD (PERSONALITY)

RELAXING + THERAPEUTIC
NEW START + NEW BEGINNINGS

'YOU CAN BREATHE NOW'
COLD (PERSONALITY)

MALE PERSPECTIVE, FEMALE PERSPECTIVE

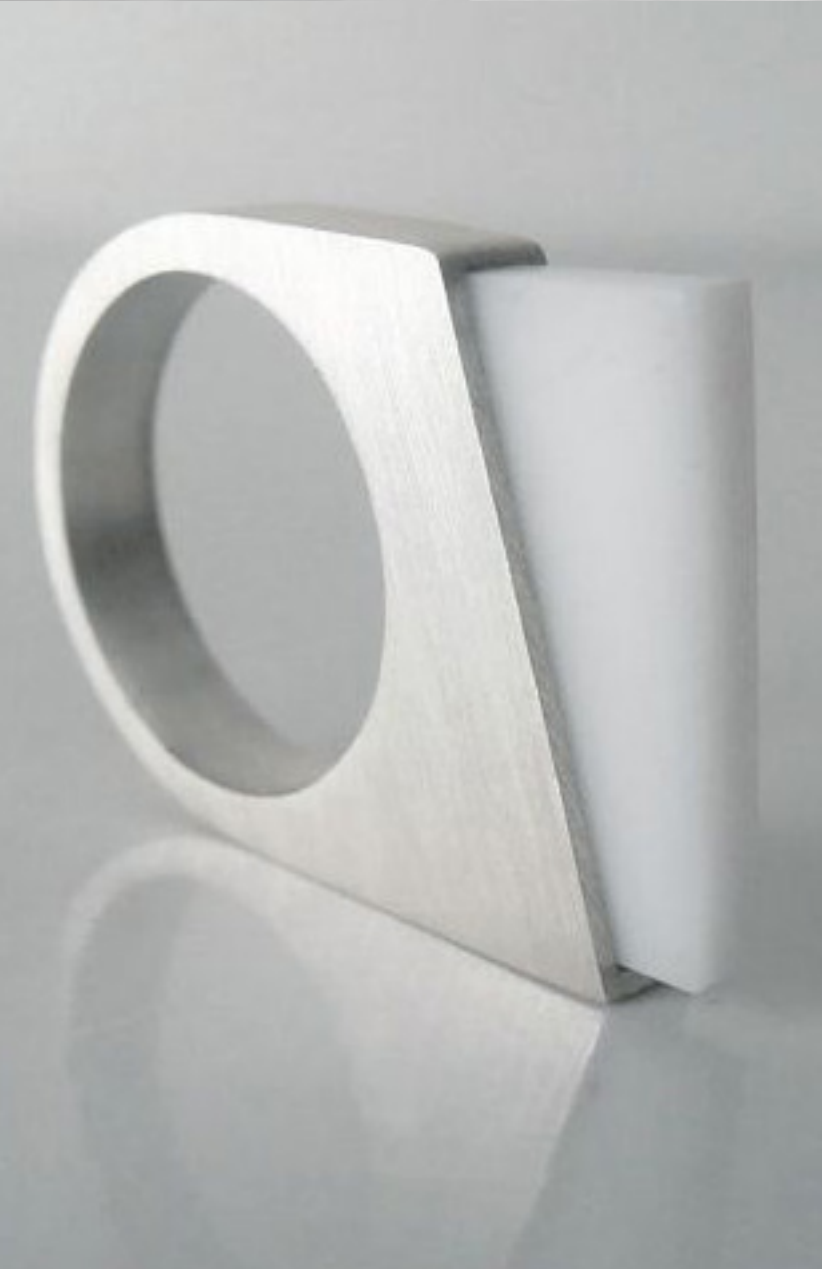



©Kiwon Wan



METAL RESEARCH

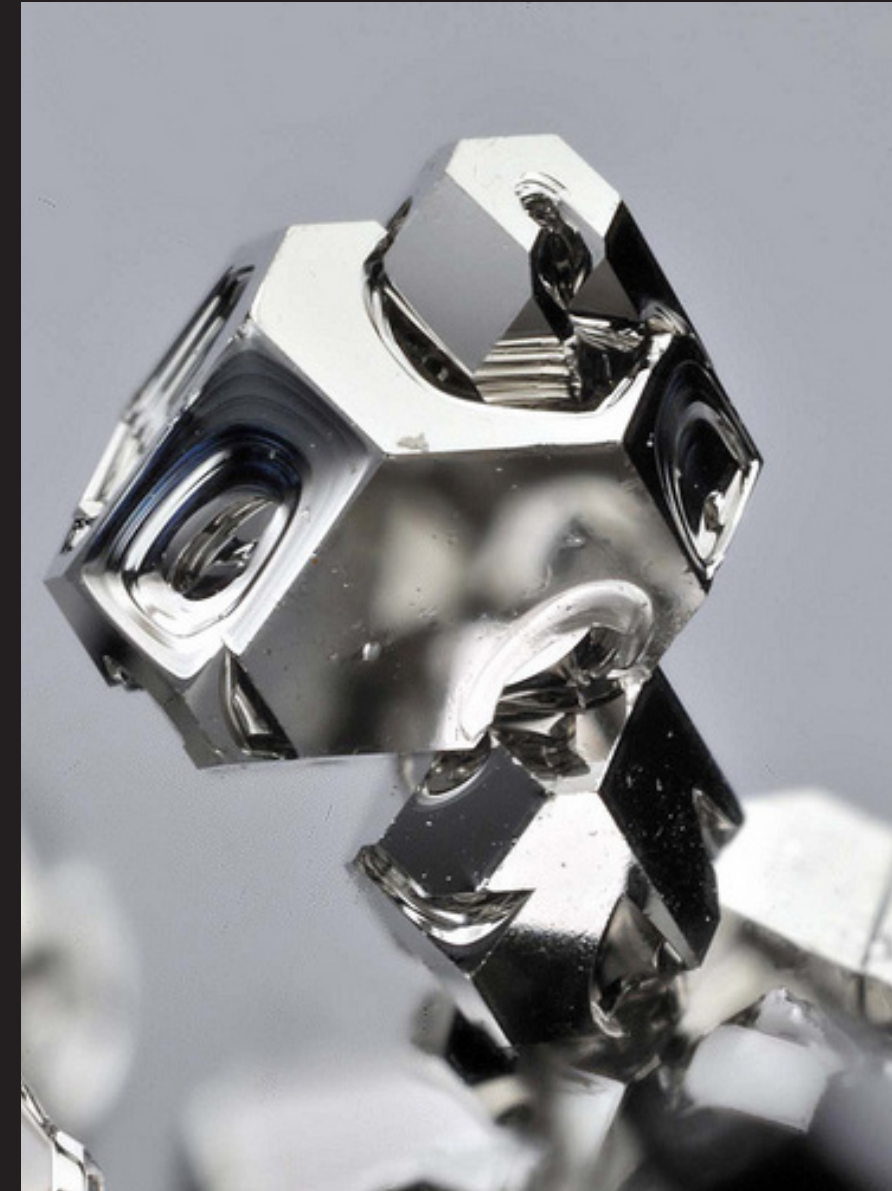

PLATINUM – PURE, PRECIOUS METAL, HYPOALLERGENIC, 4X, MORE DURABLE THAN GOLD, BLENDS WELL WITH VARIOUS METALS AND STONES, SILVERY-WHITE LUSTER, DURABLE

STERLING SILVER – DURABLE, LONG-LASTING, WHITE LUSTROUS HUE, OXIDIZES OVER TIME

PALLADIUM – BRIGHT WHITE APPEARANCE, MALLEABLE, MORE AFFORDABLE ALTERNATIVE TO ‘PLATINUM’

BRASS + GOLD PLATING

RAINBOW MOONSTONE

- SCATTERS LIGHT, UNLIKE MOST STONES, WHICH EITHER ABSORB LIGHT OR LET LIGHT PASS THROUGH THEM COMPLETELY
- CREATES APPEARANCE OF GLOW FROM WITHIN
- STRONG CONNECTION TO SPIRITUAL WORLD
- LEADING SOURCE: SWITZERLAND



ETHIOPIAN OPAL



- CHARACTERIZED BY TRANSLUCENCE
- DELICATE, BUT VIBRANT WITH ENERGY
- DISPLAYS OPALESCENCE (REFLECTIVE COLORS) AGAINST WHITE, DARK BROWN, OR BLACK BACKGROUNDS
- LEADING SOURCE: AUSTRALIA

- IMPERFECT PEARLS WITH IRREGULAR SHAPES,
DENTED AND UNEVEN SURFACES
- ORGANIC SHAPE AND FORM
- LOTS OF LUSTER
- VERY PERSON--EACH 'IMPERFECTION' IS APPRECIATED FOR
ITS UNIQUENESS AND INDIVIDUALITY
- GREATLY USED IN VICTORIAN & ART NOUVEAU PIECES
- DIFFERENT TYPES: CROSS, COIN

BAROQUE PEARL



LABRADORITE



- STONE THAT REFRACTS LIGHT OF IRIDESCENT FLASHES OF PEACOCK
BLUE, GOLD, PALE GREEN, OR COPPER RED
- OFTEN GRAY-GREEN, BLUE GREEN, GRAY, BLACK/GRAYISH-WHITE
- CONSIDERED TO TEMPER THE NEGATIVE ASPECTS
OF OUR PERSONALITIES

MASCULINE FEATURES:

- SPARKLE
- HIGH POLISH
- CUFF LINKS, STICK PINS
- SIGNET RINGS, BAND RINGS

FEMININE FEATURES:

- MORE TEXTURE
- MATTE FINISH
- ARM CUFFS, DROP EARRINGS,
- BROOCH, HAIR JEWELRY

UNISEX JEWELRY

MIXED- METAL COMBINATIONS

WARM-COOL PAIRING

CLEAN LINES, BOLD SCALE

SUBSTANTIAL WEIGHT

SYMBOLS/MOTIFS = NON-GENDER SPECIFIC

FEMININE DESIGN, GENDERLESS IMAGERY

(IMAGERY THAT IS APPRECIATED
BY BOTH GENDERS)

LARGER SIZE RANGE

LANGUAGE (LACK OF TEXT)

GENDER FLUIDITY

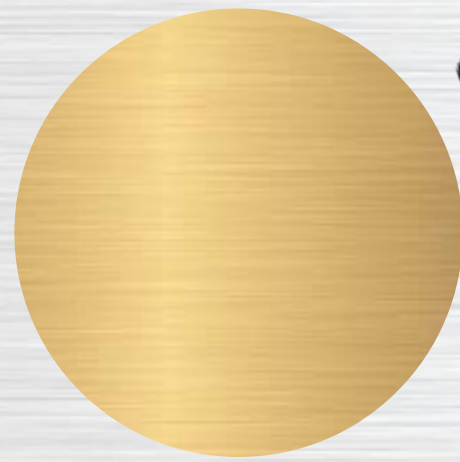
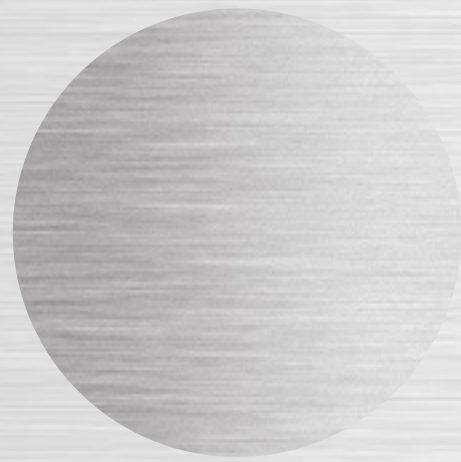

ABSTRACT GENDER-FLUID
SHAPE + FORM

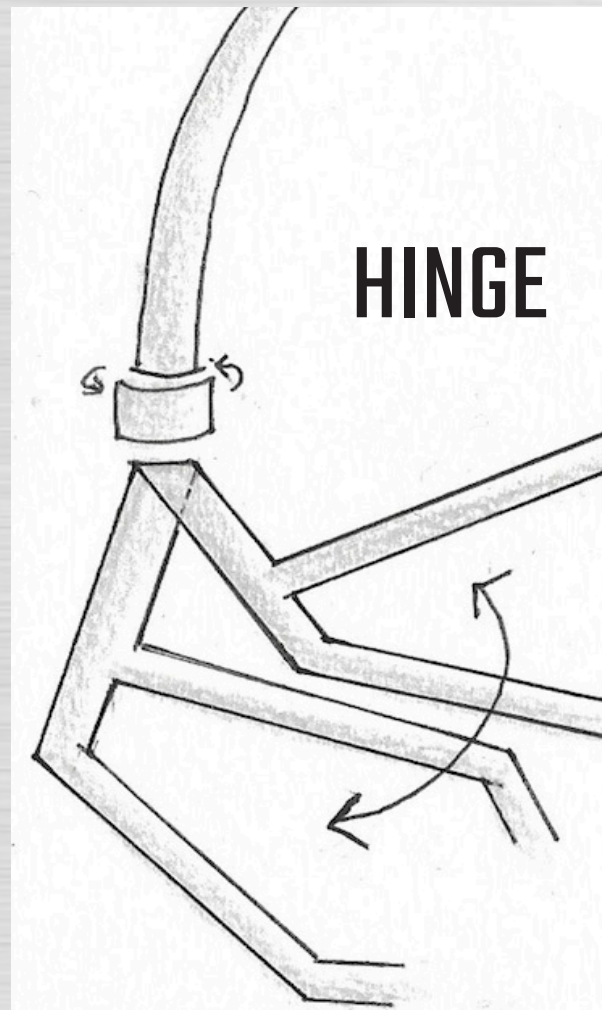

HINGE

- ASPECT TO ALLOW AN ADJUSTABLE, MOVABLE FORM
- PROMOTES MULTIFUNCTIONALITY
- ALLOWS FOR DIFFERENT VISUAL PERSPECTIVES

MATERIALS



MATERIALS
THAT REFLECT LIGHT

COLLE
PRELIMINARY SKE

CTION

TCHES + FLAT SPECS

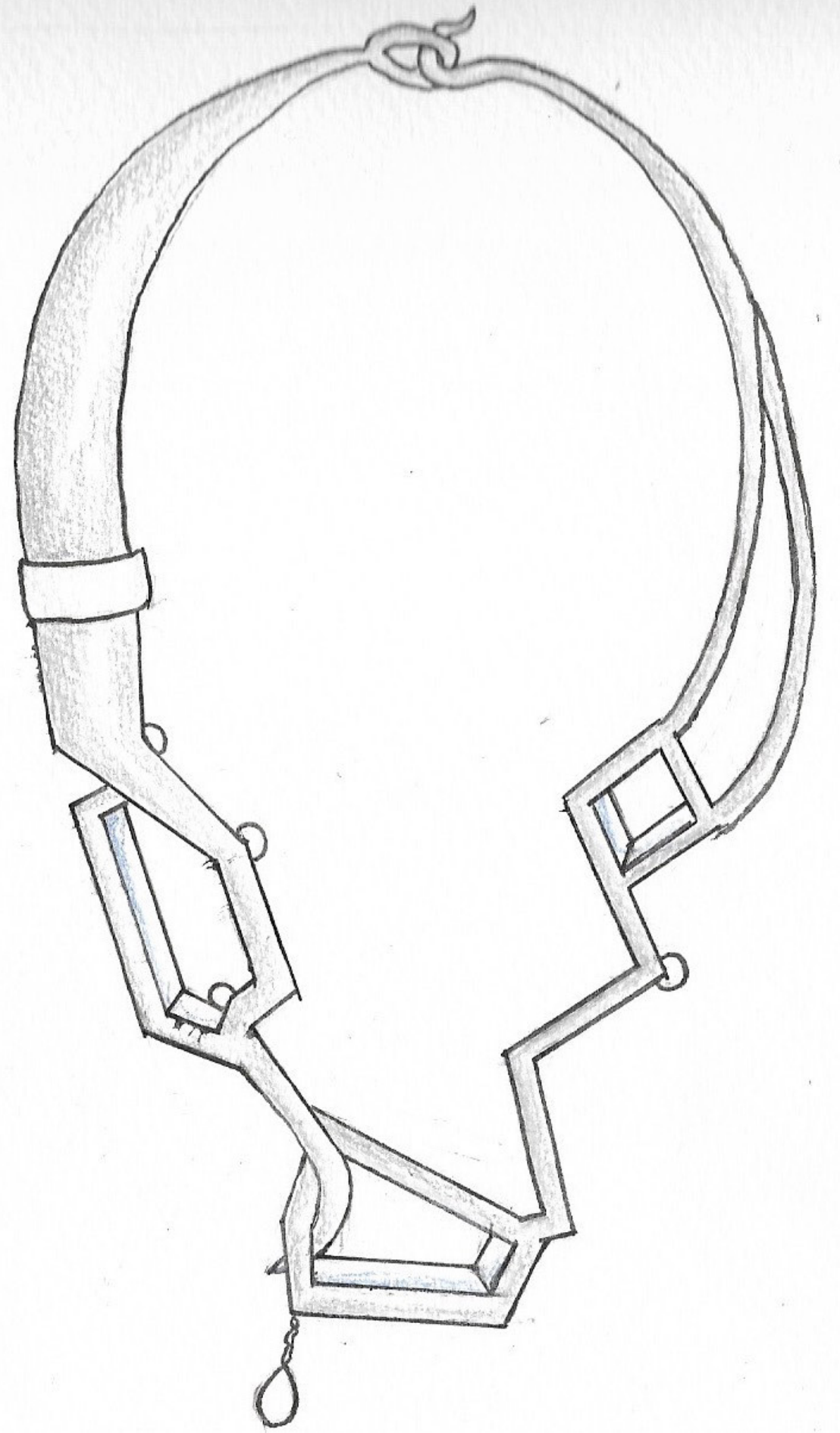
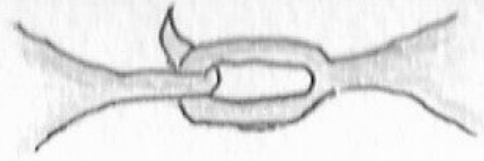
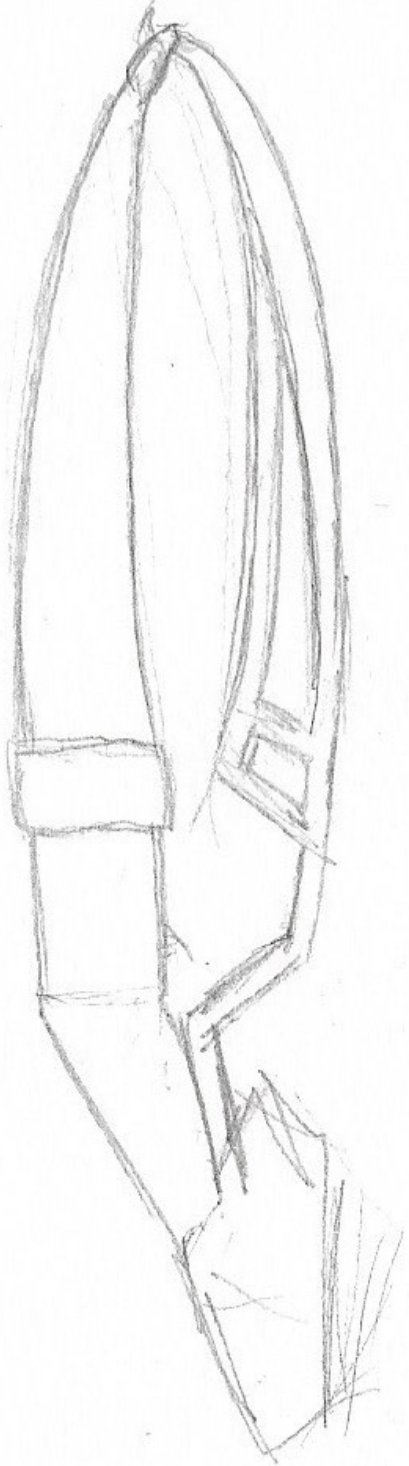
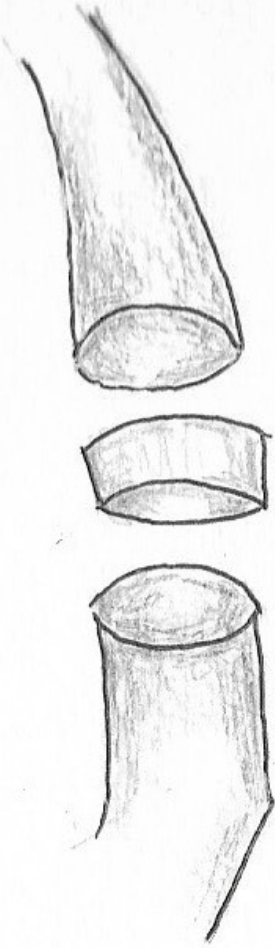
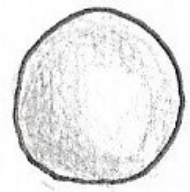
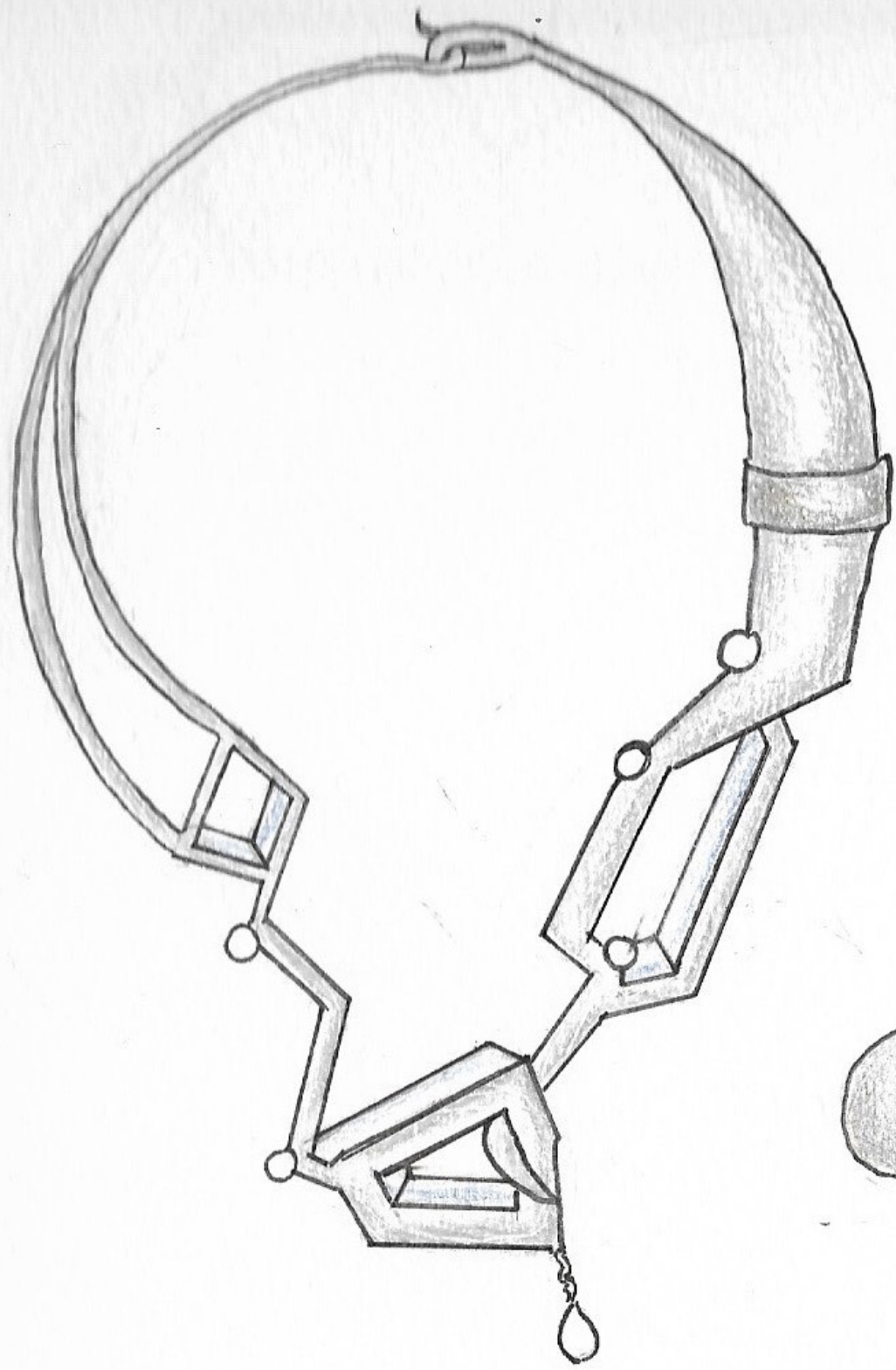

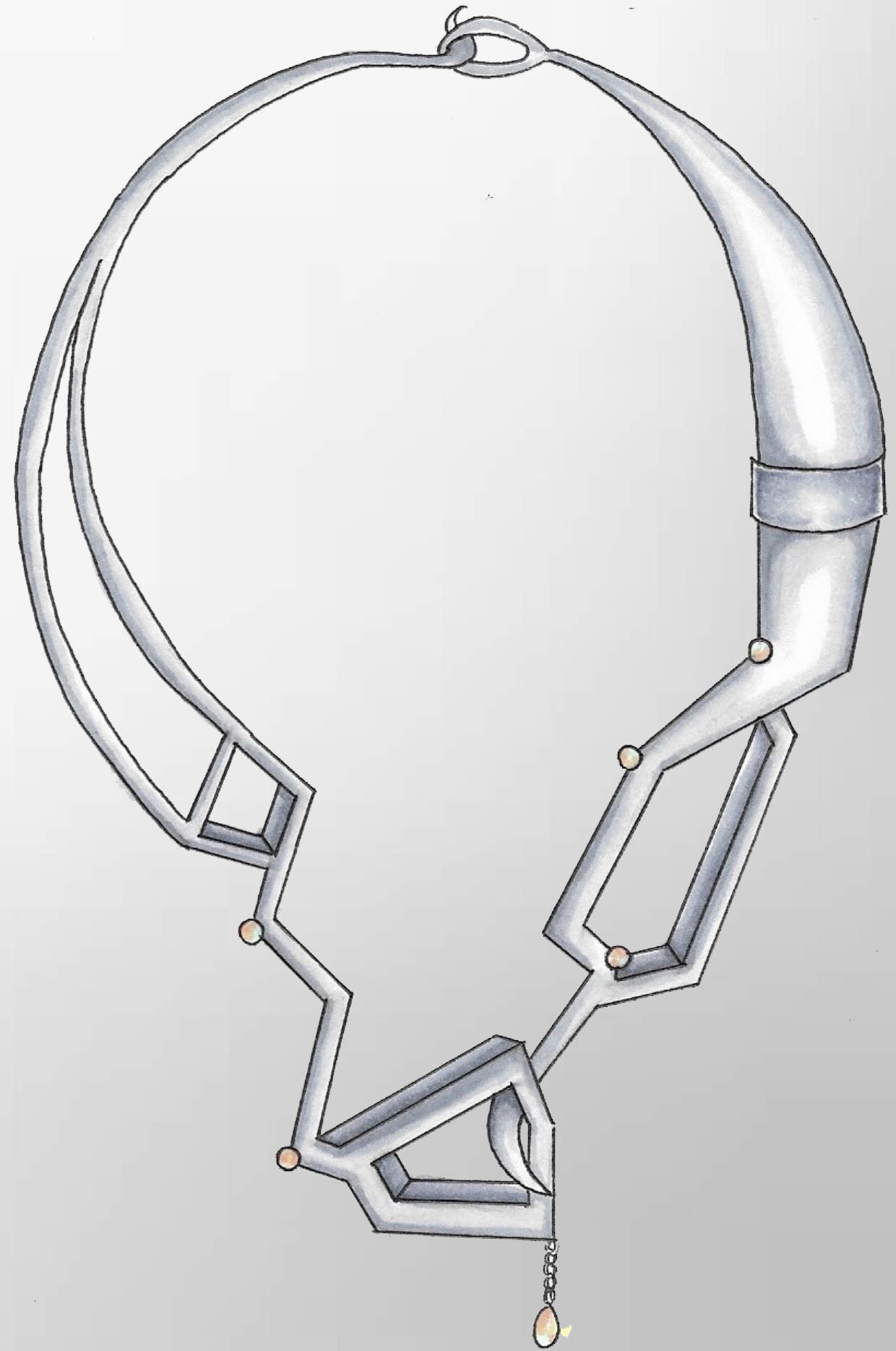
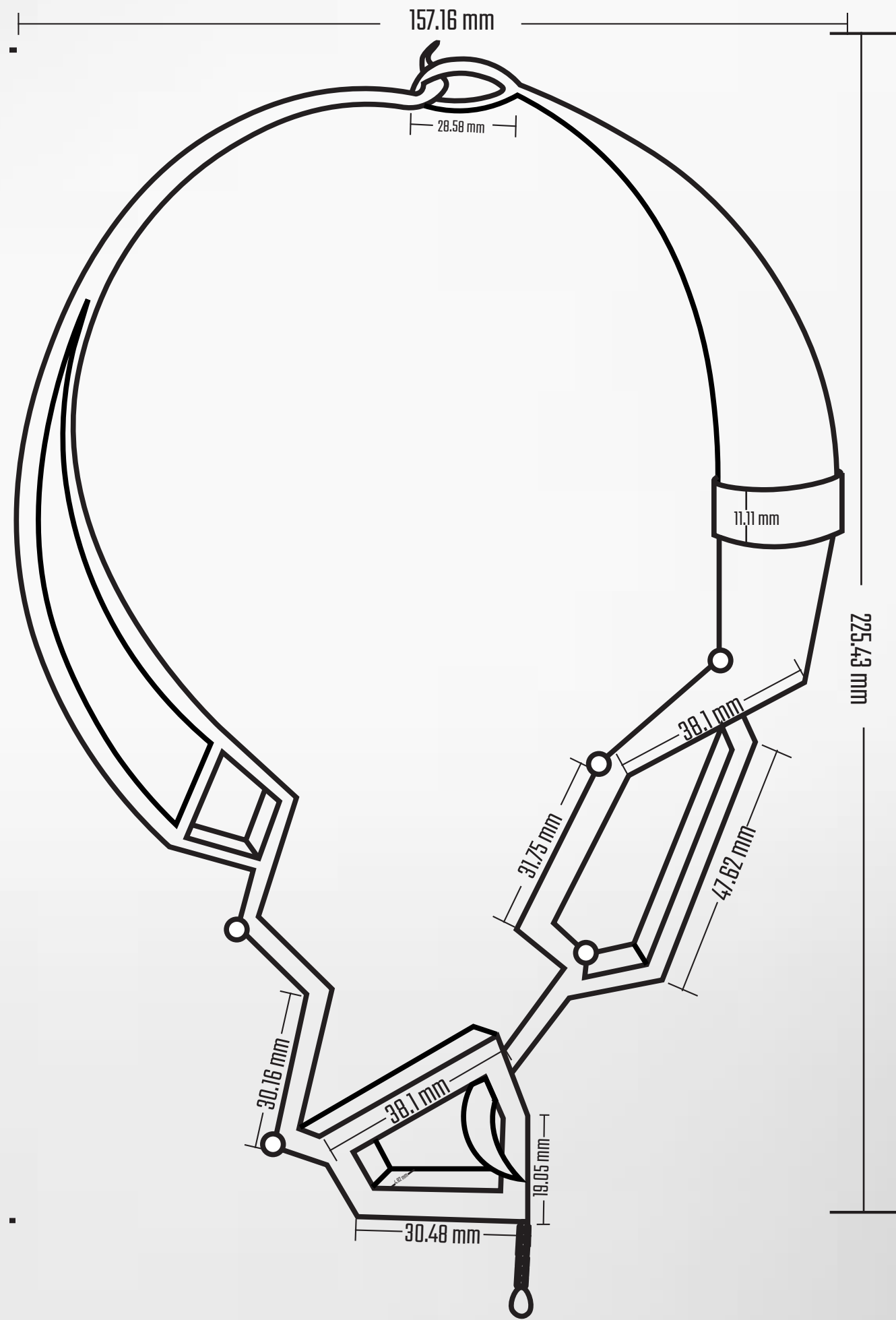

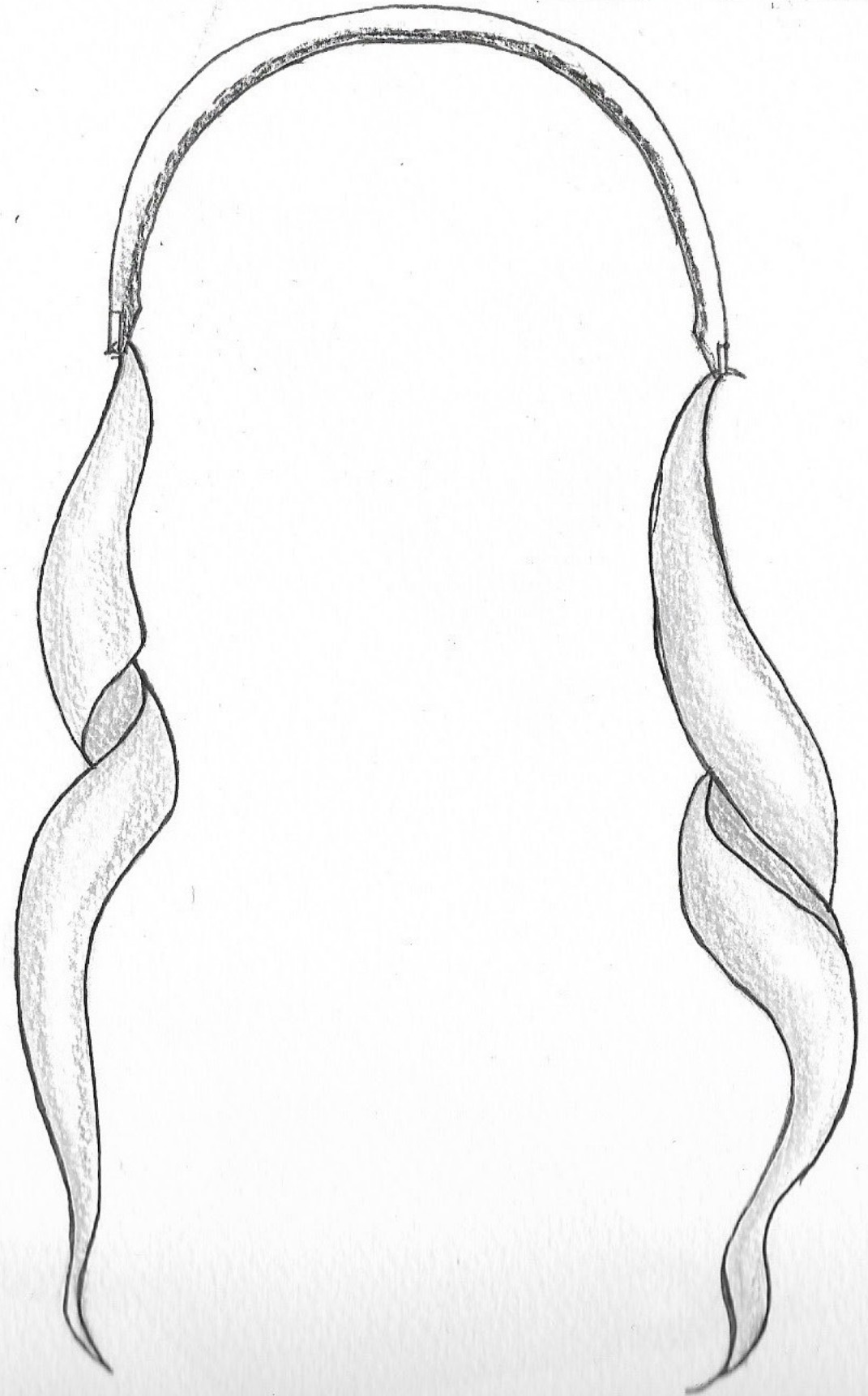
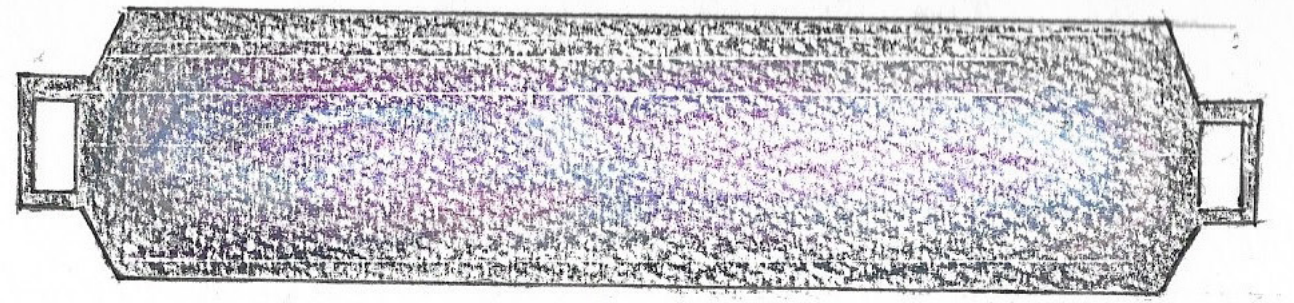
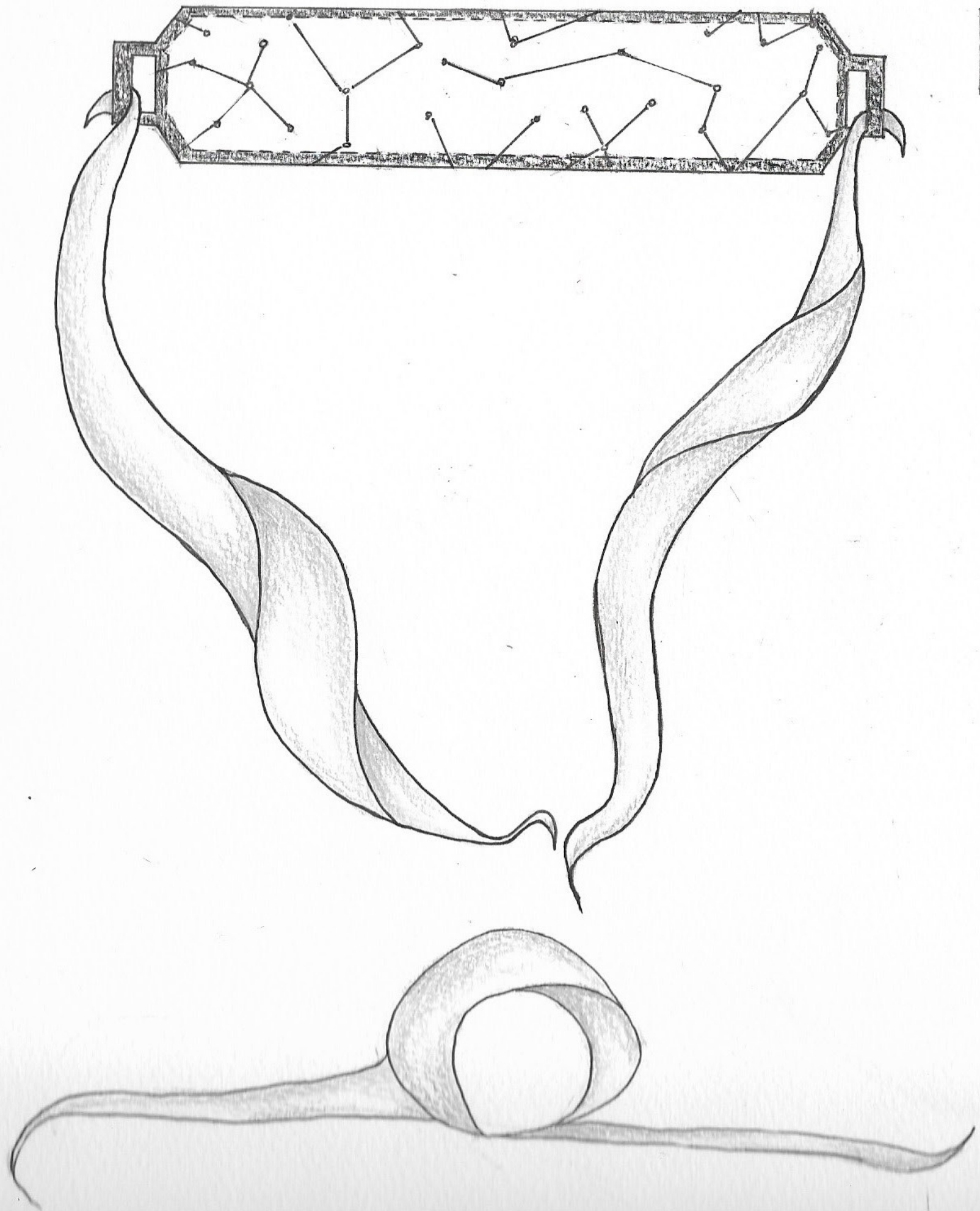

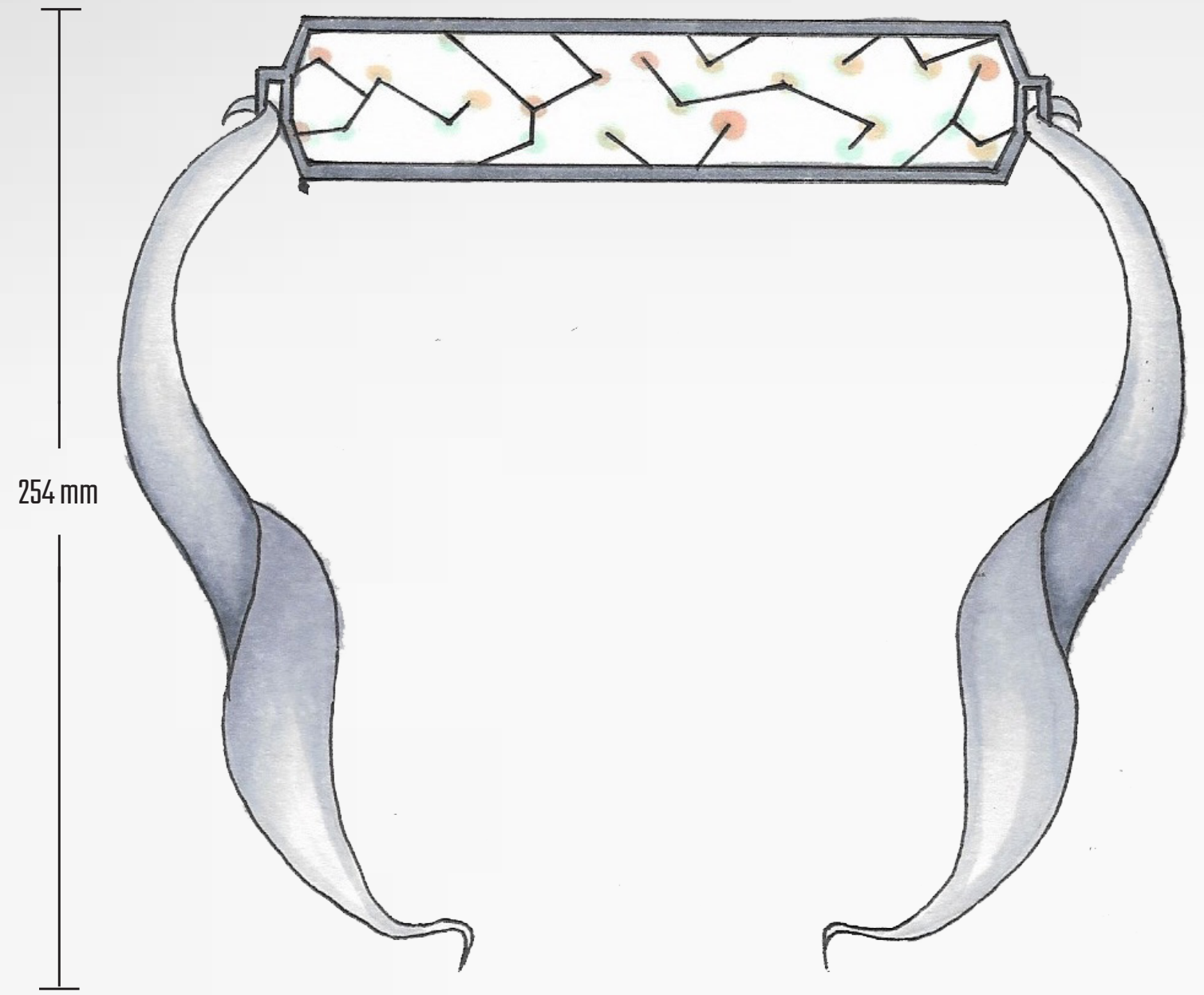
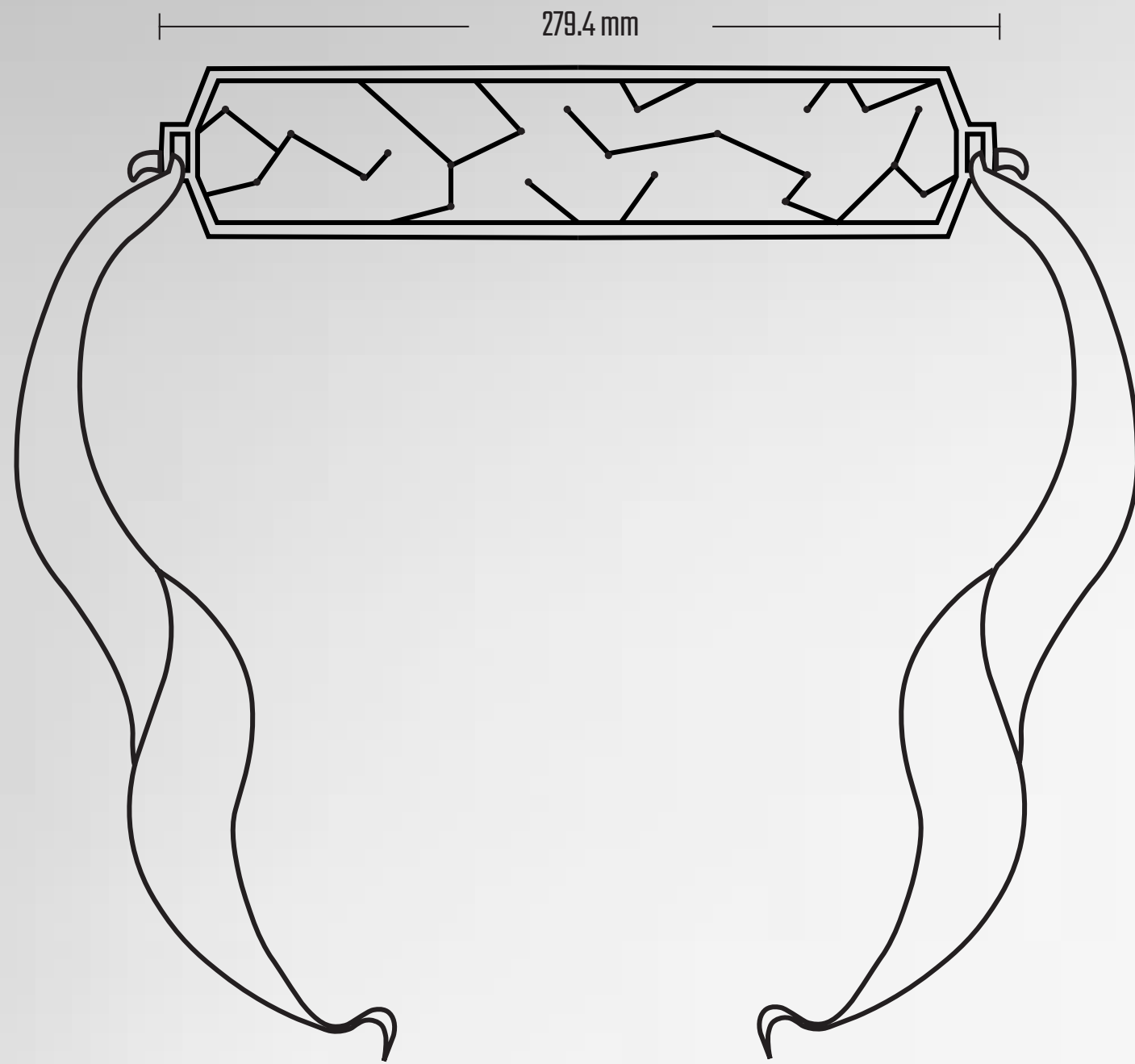

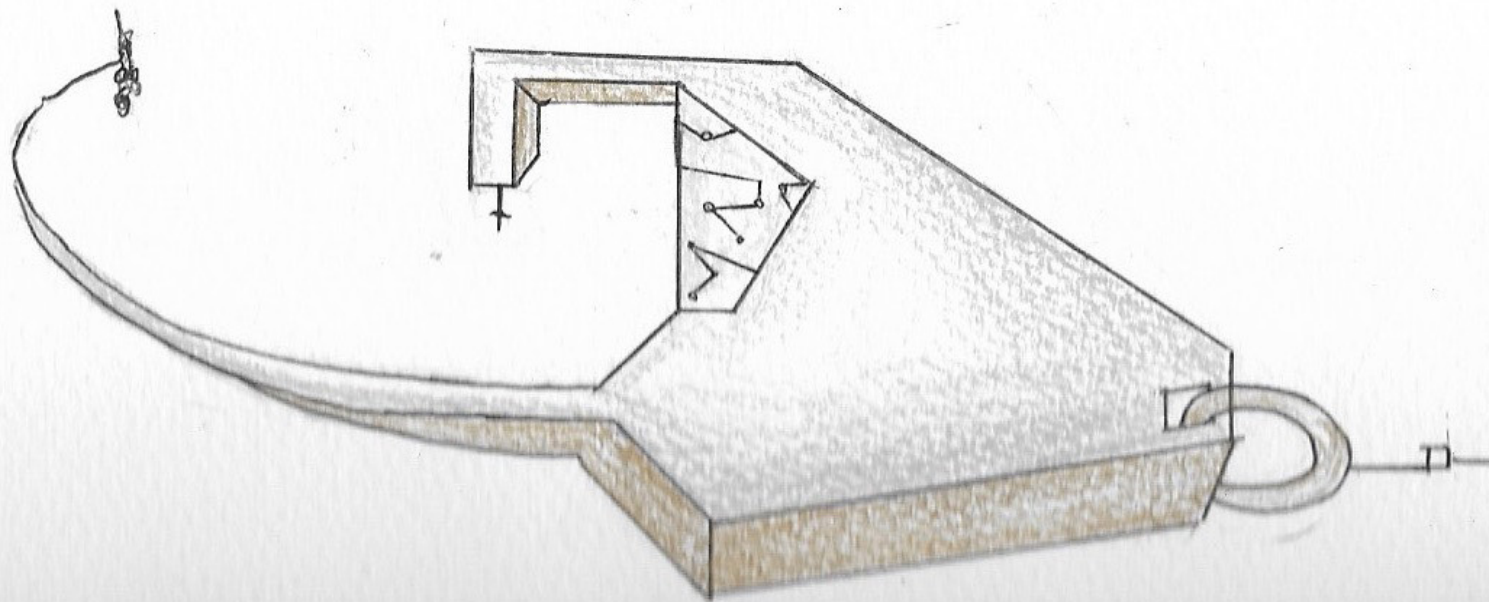
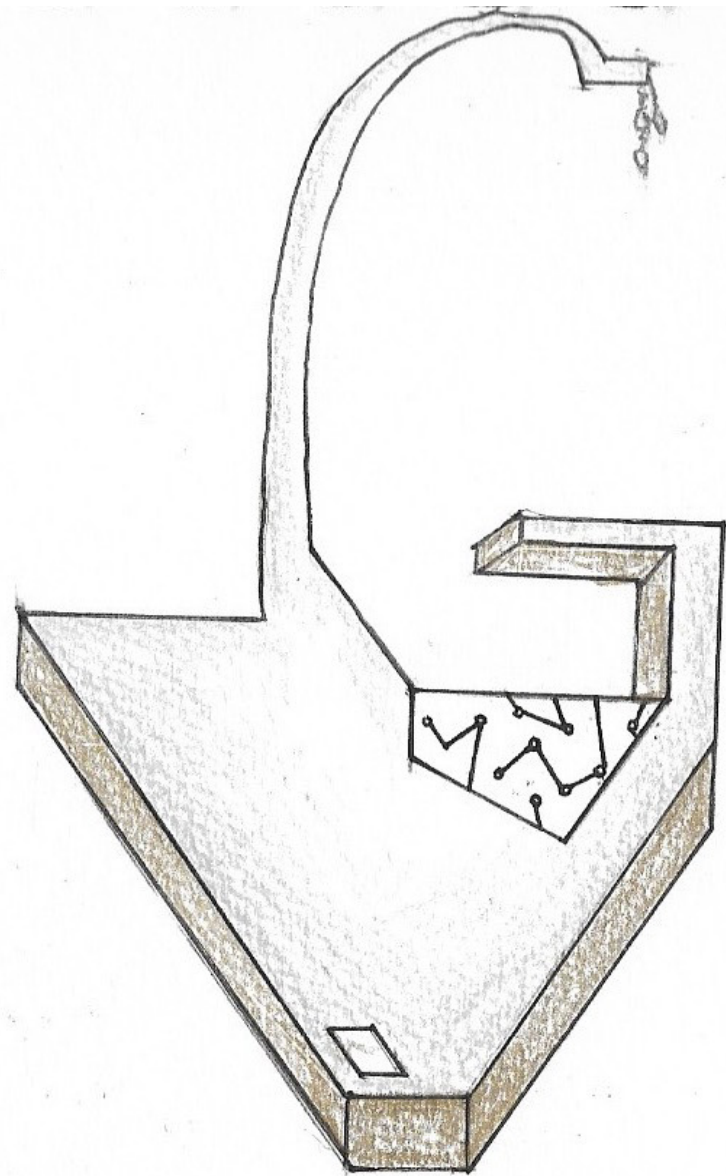
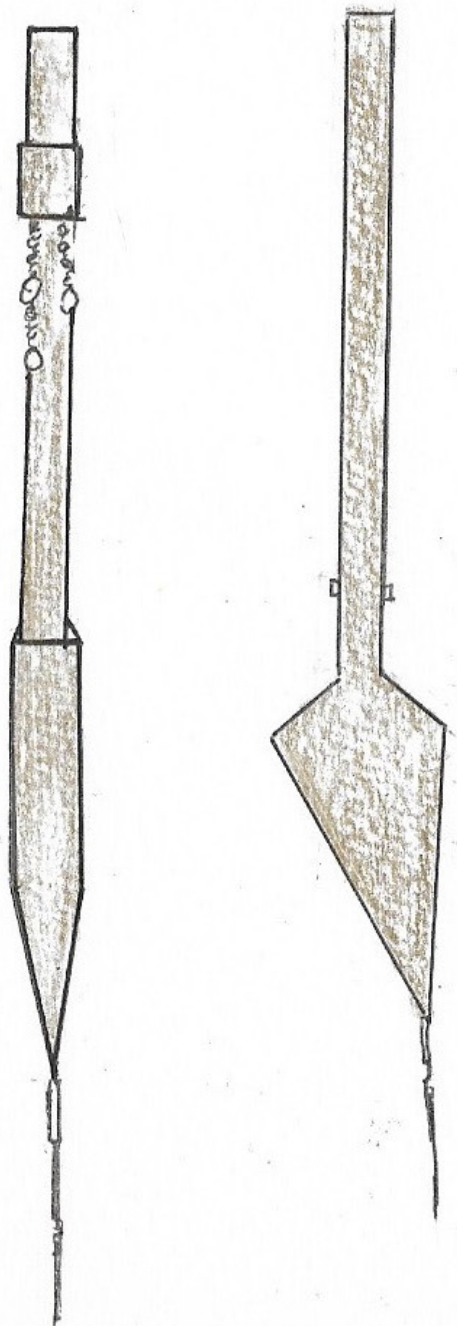
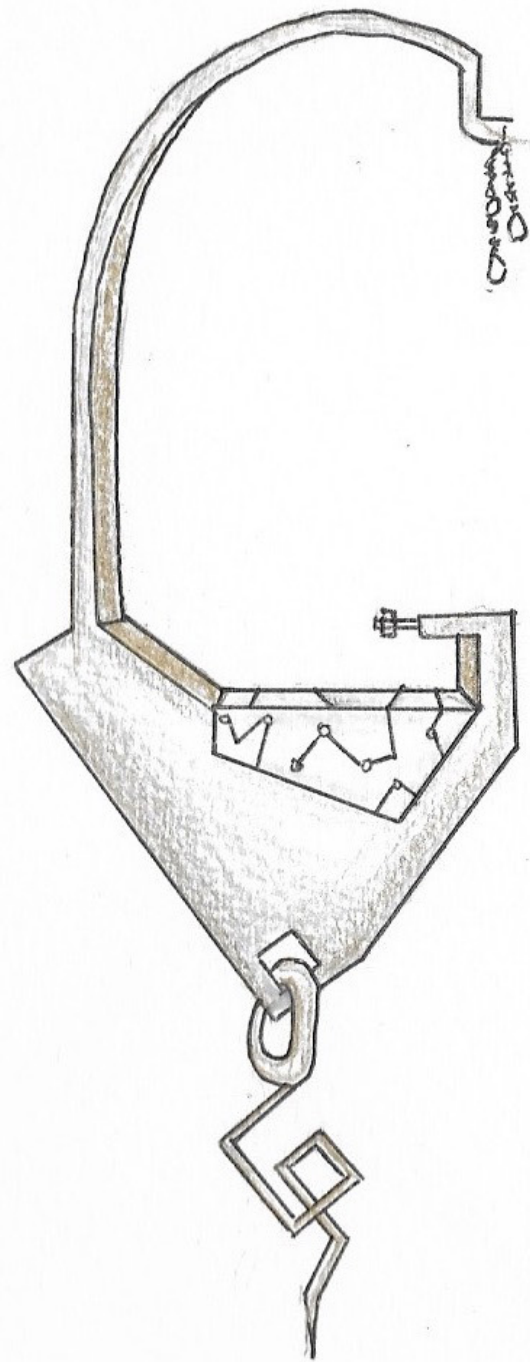

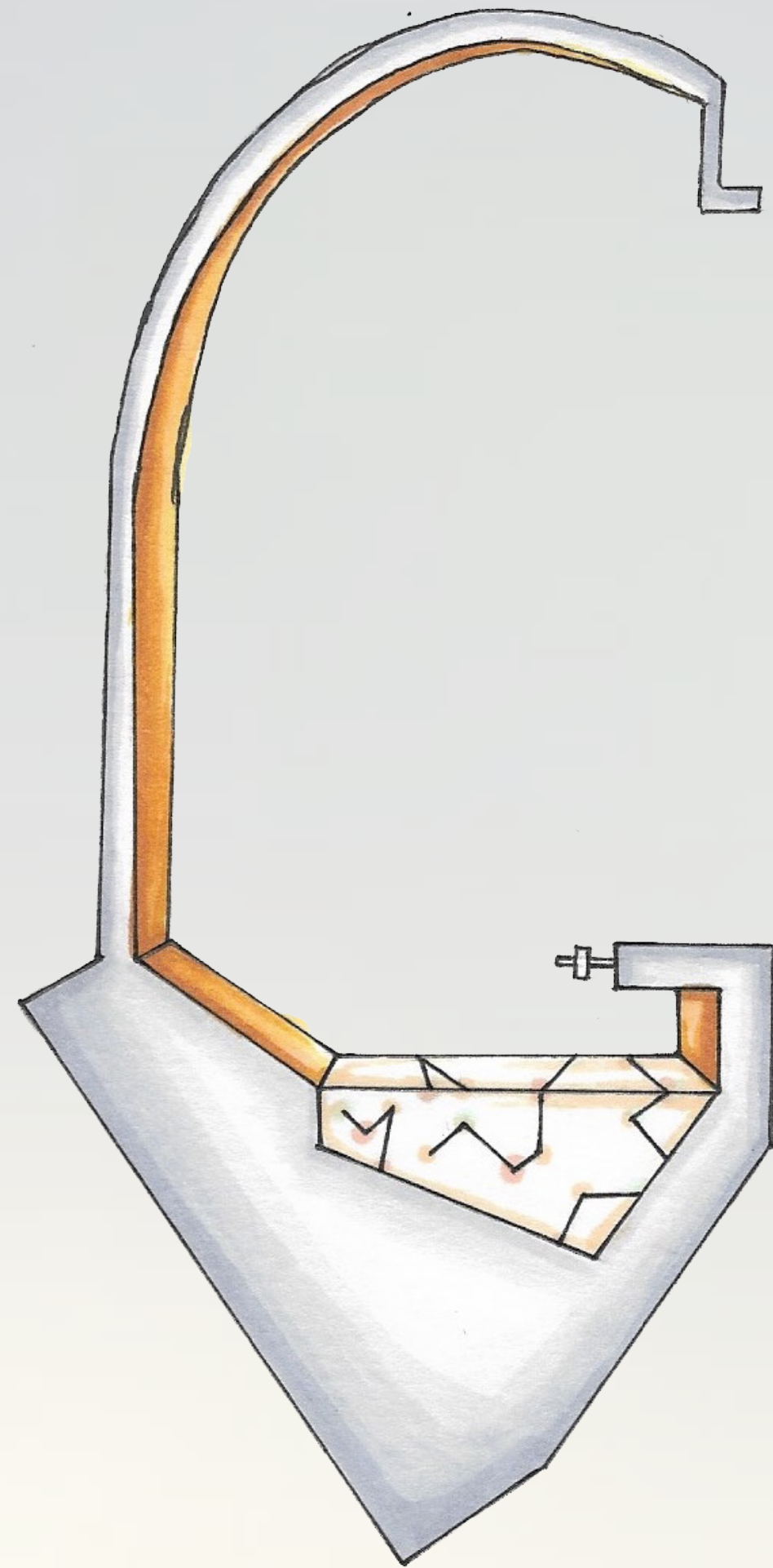
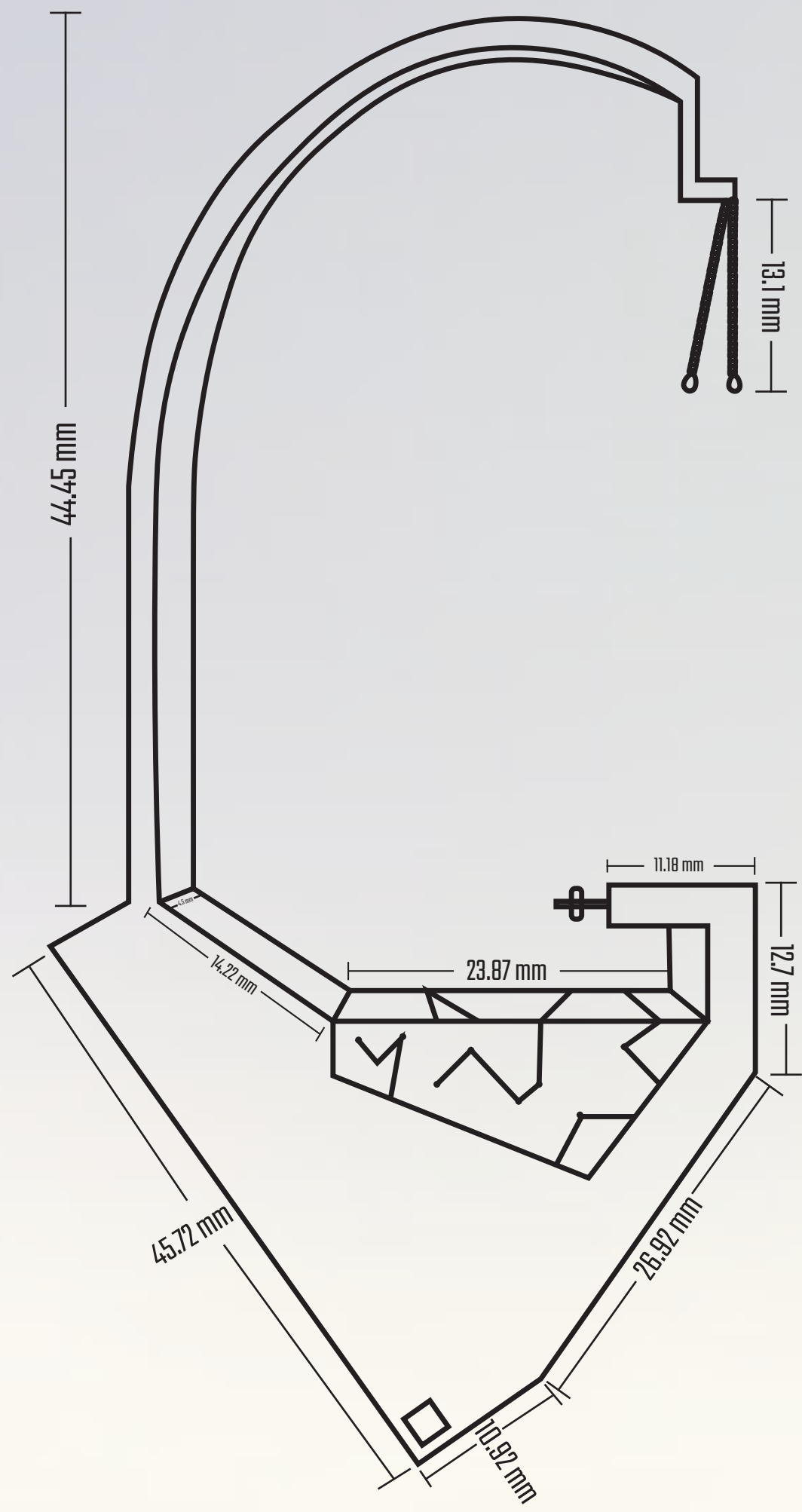

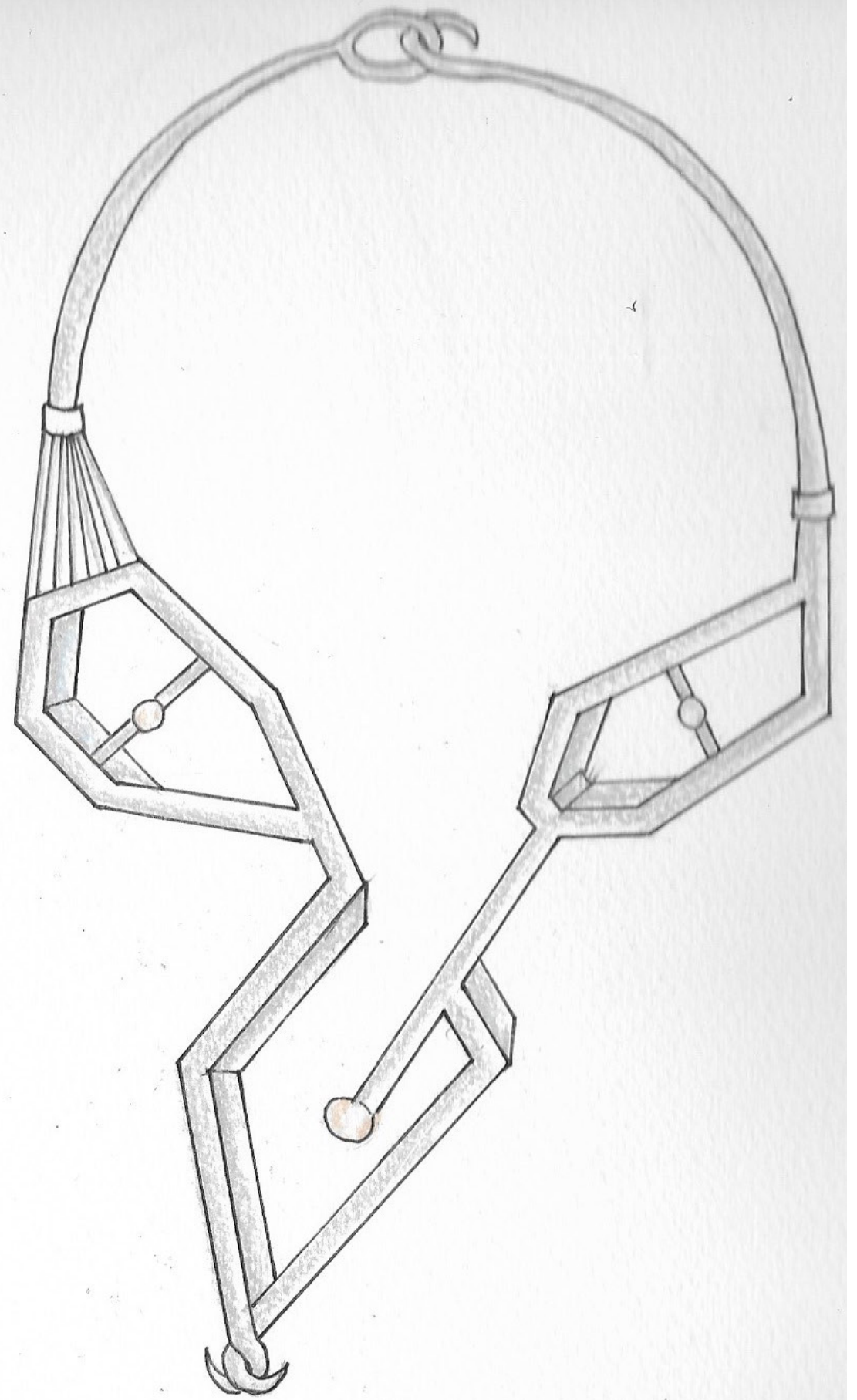
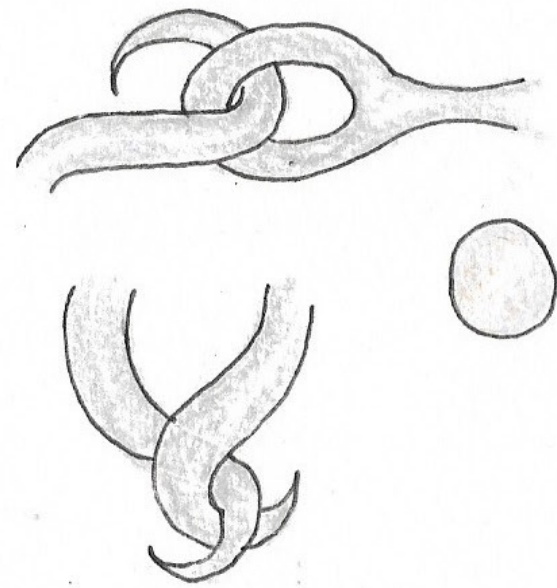
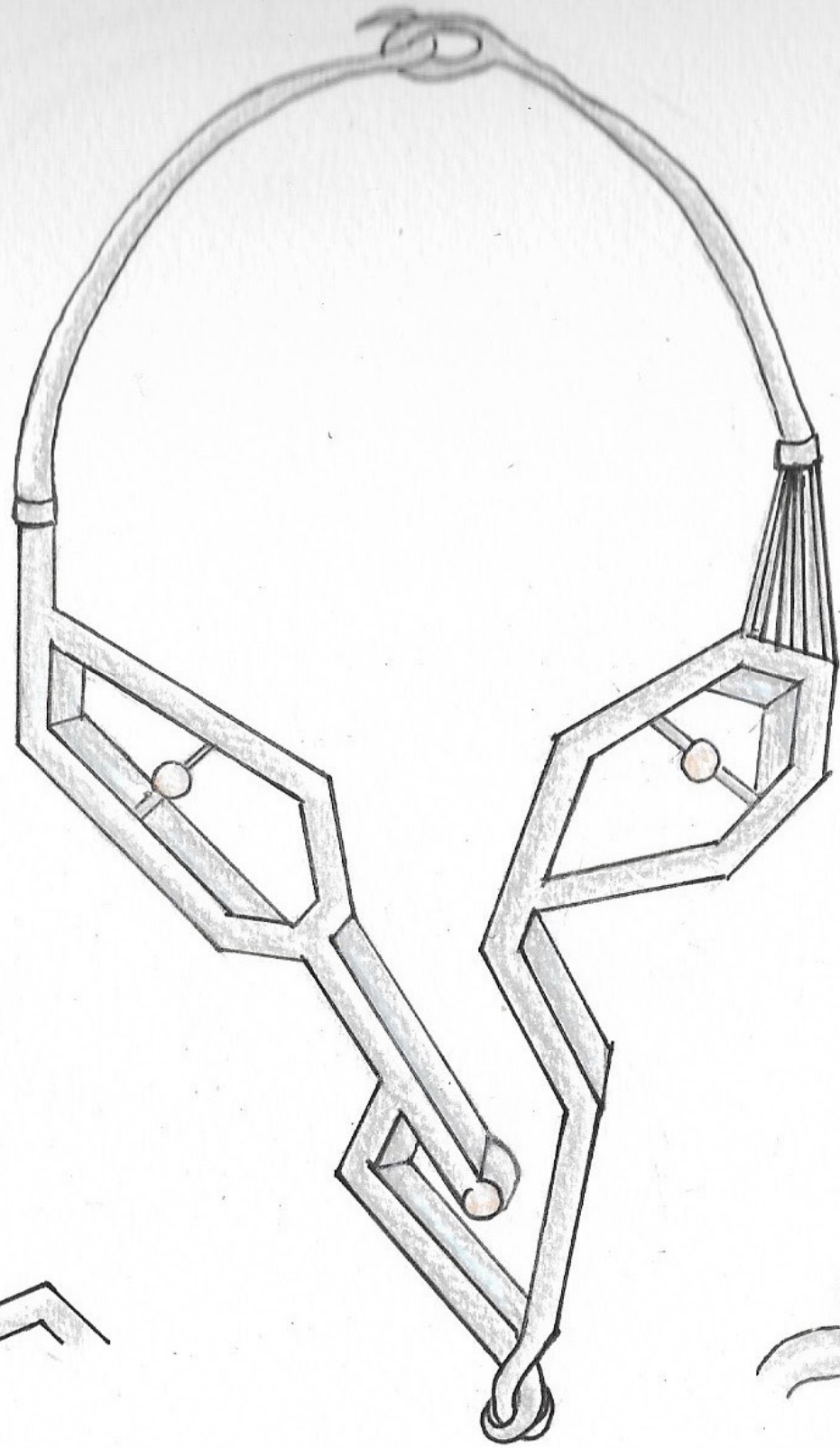
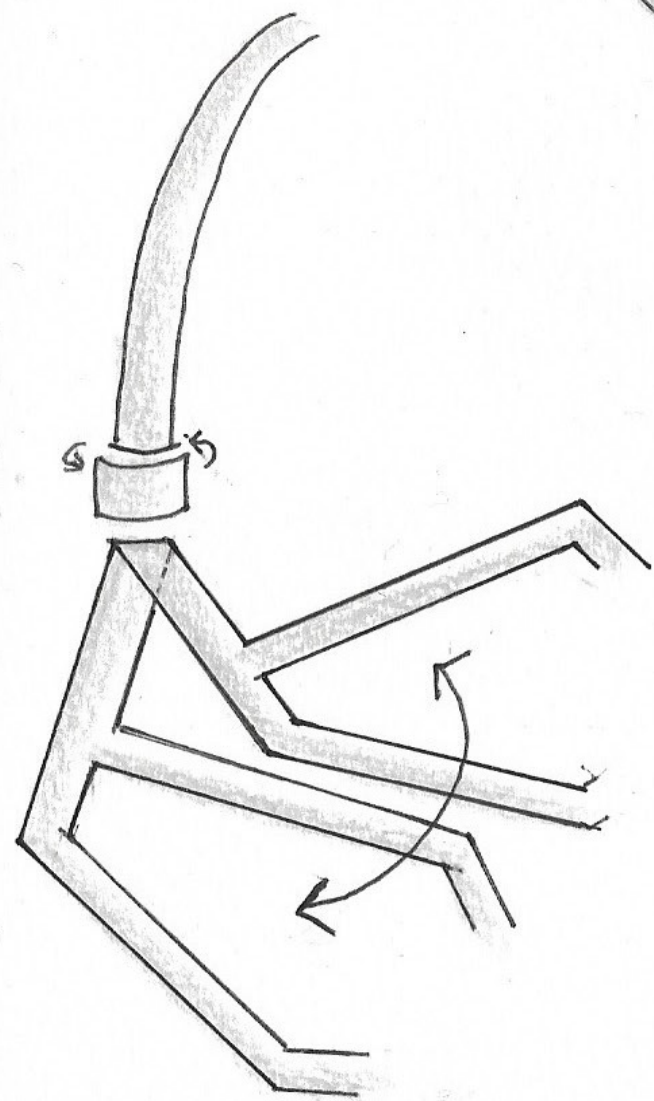

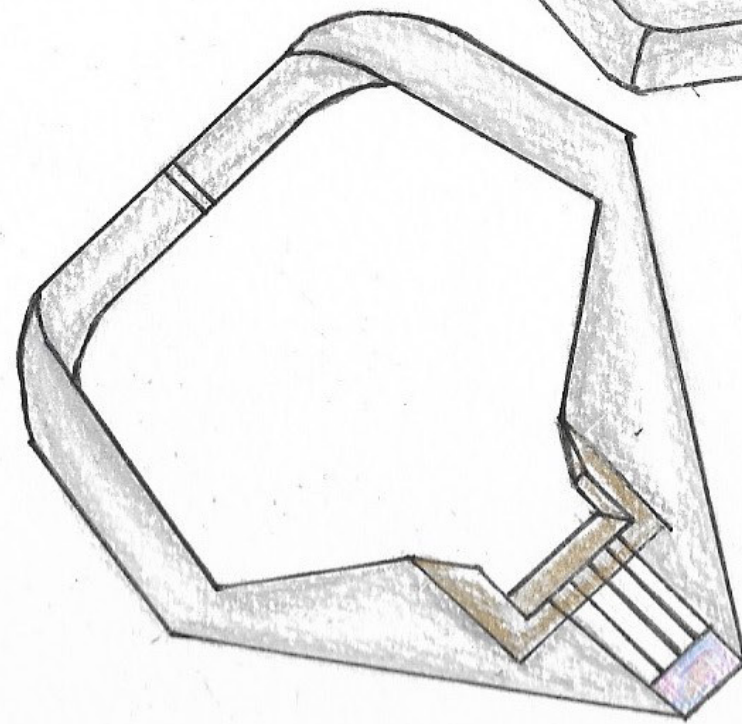
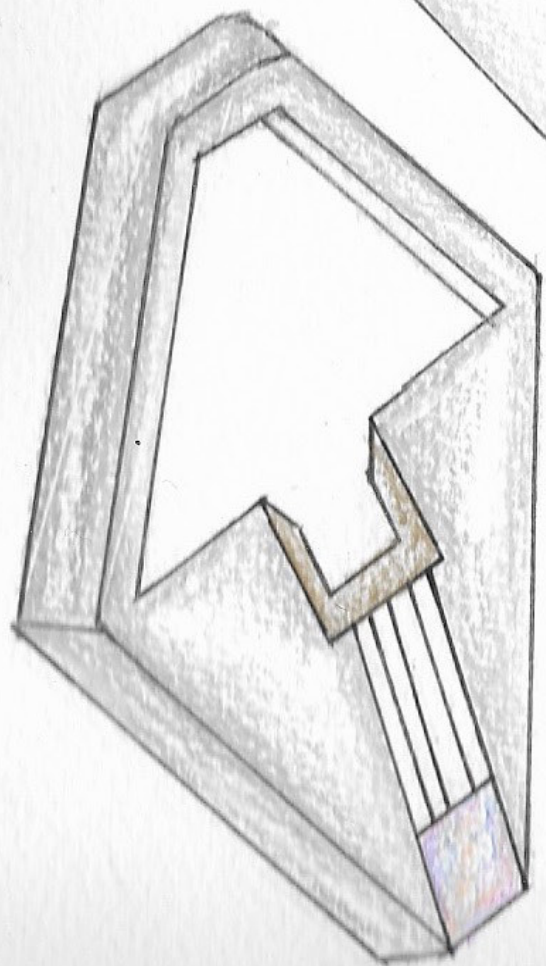
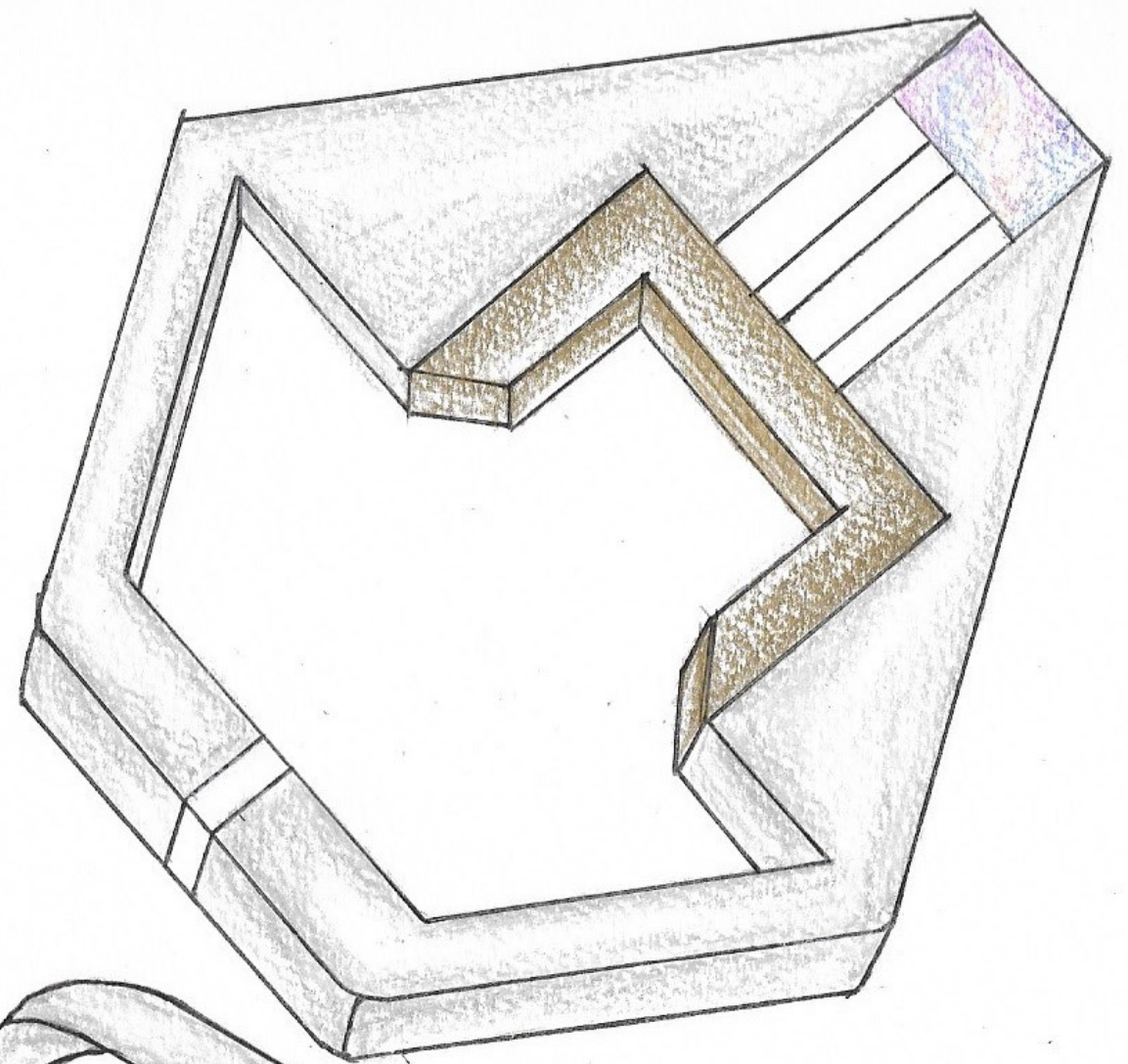
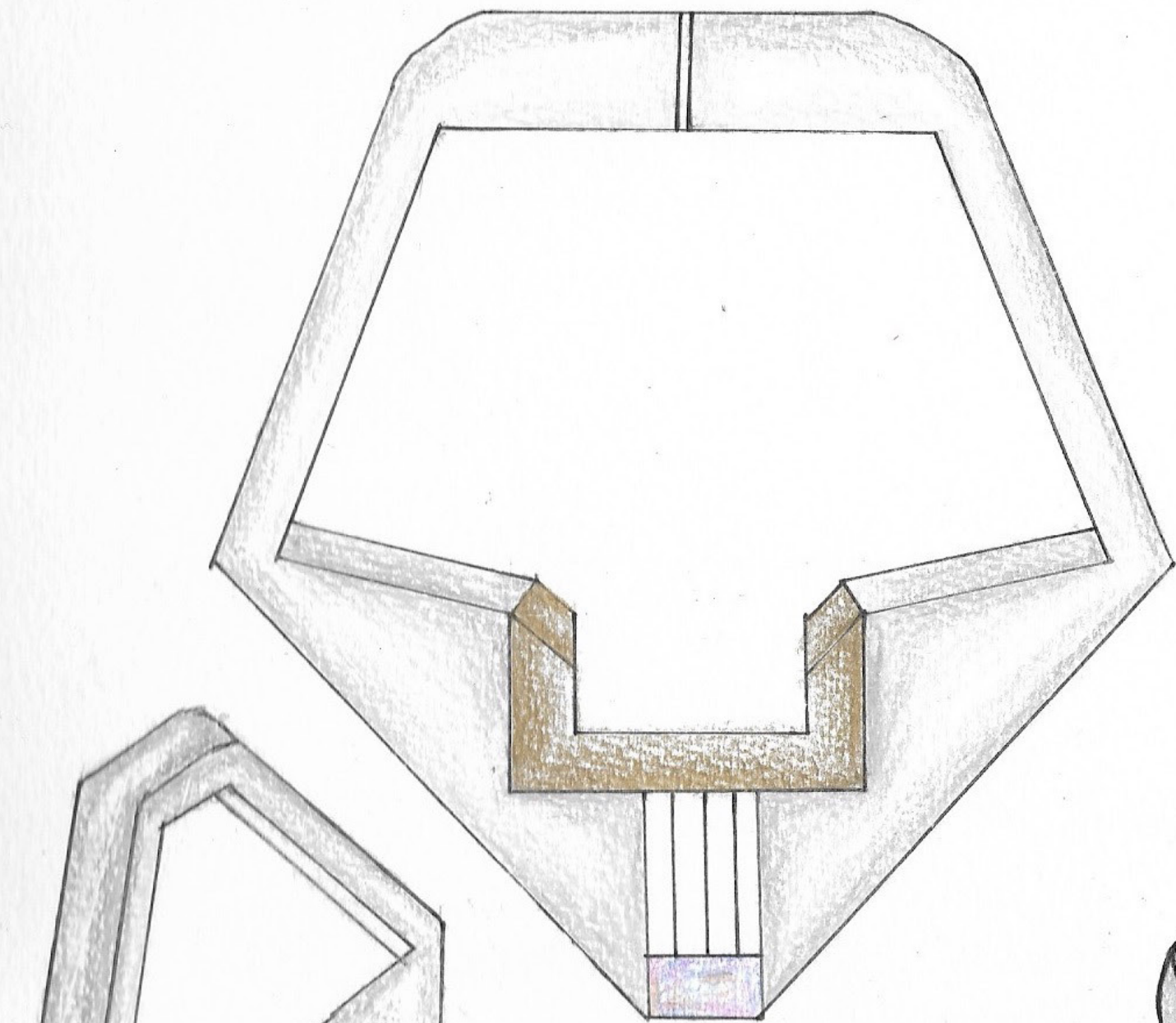

magnetic closure

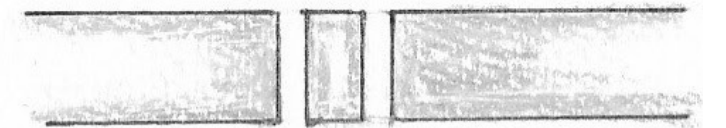

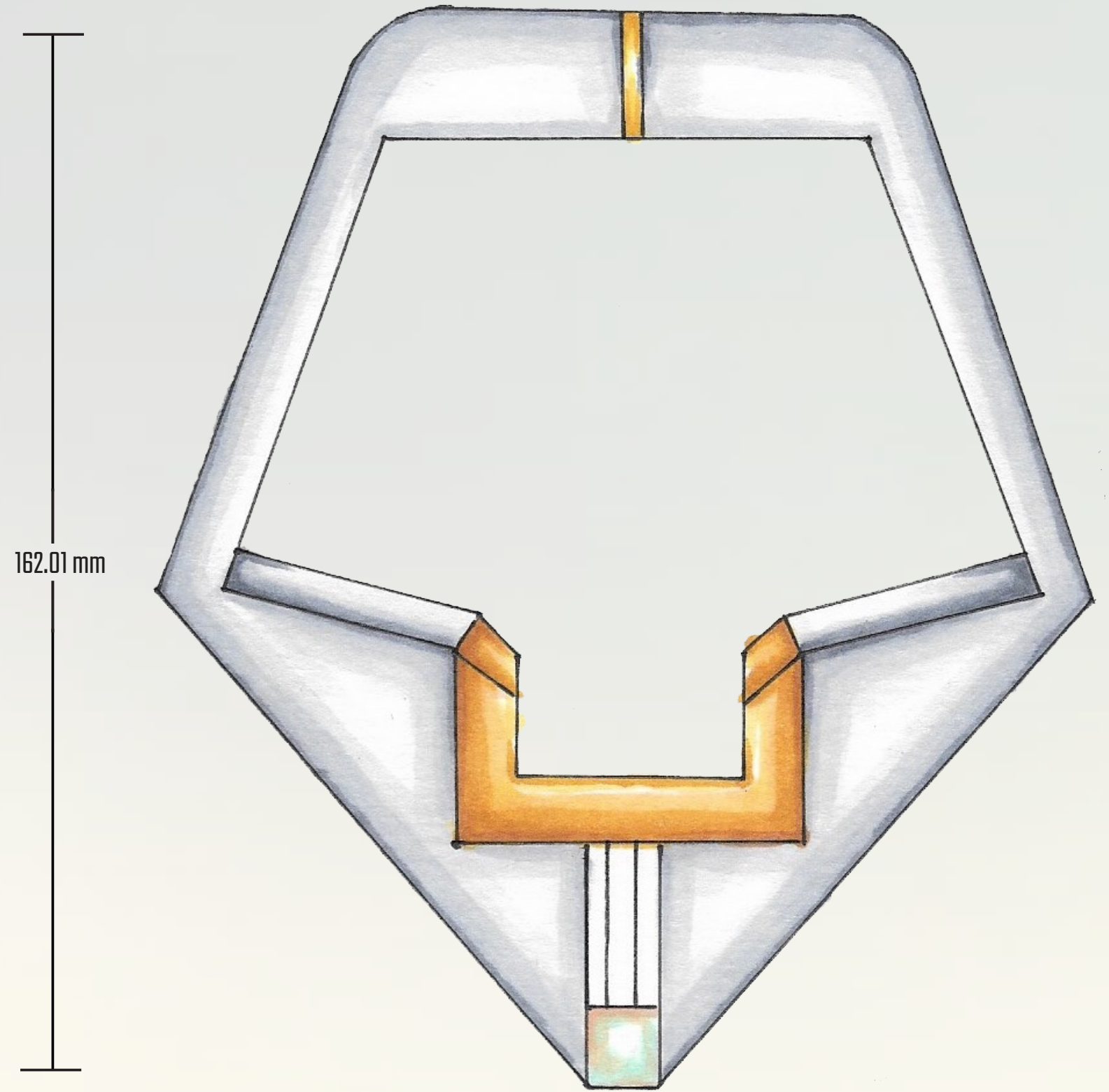
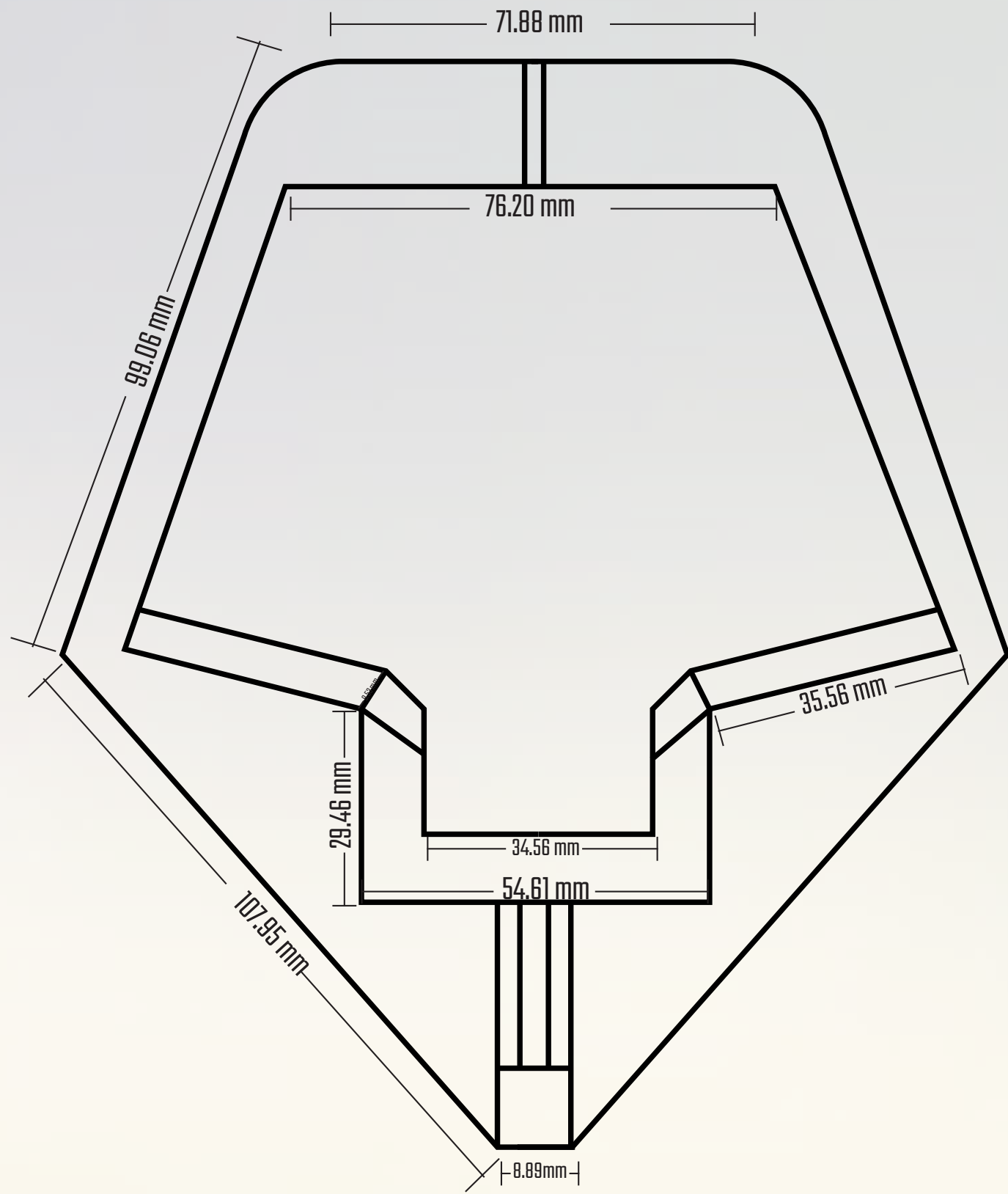

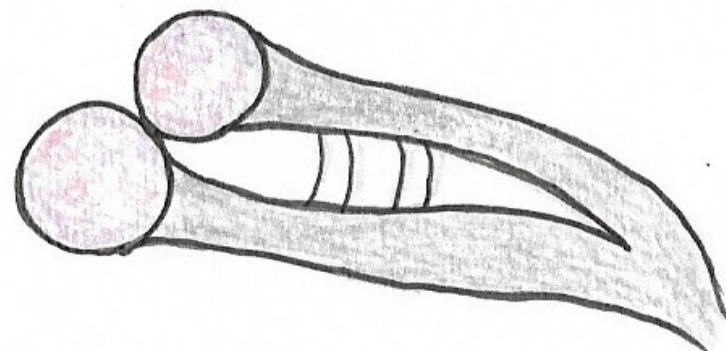
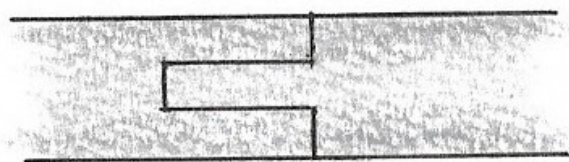
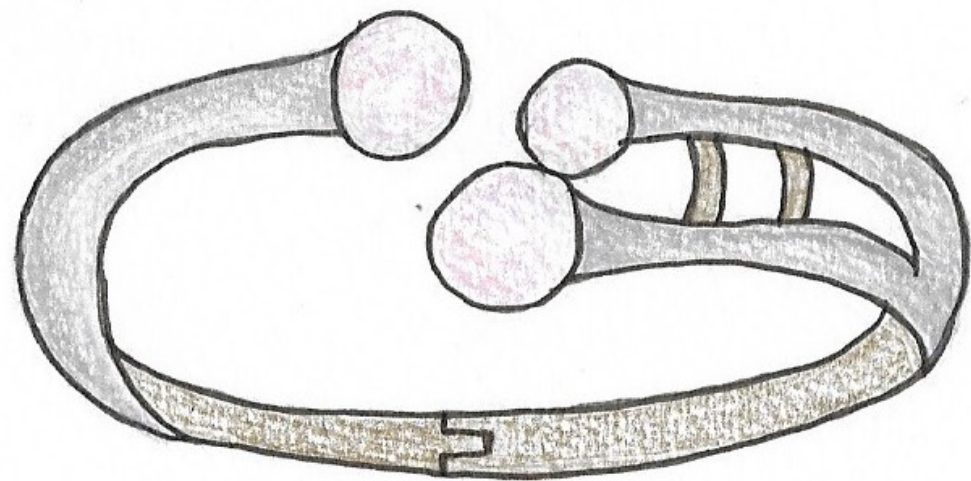
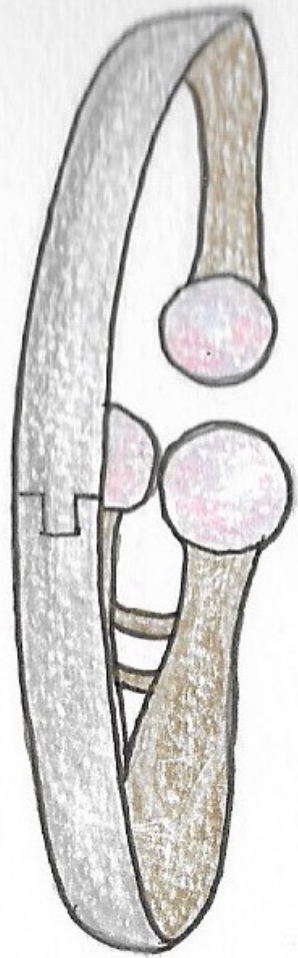
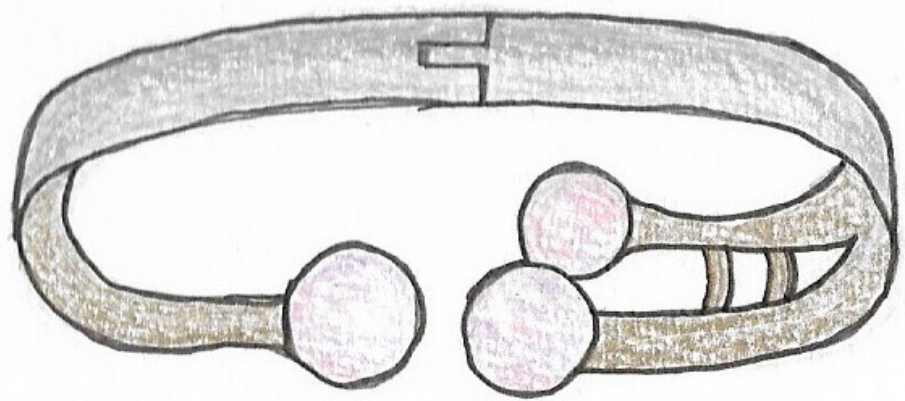

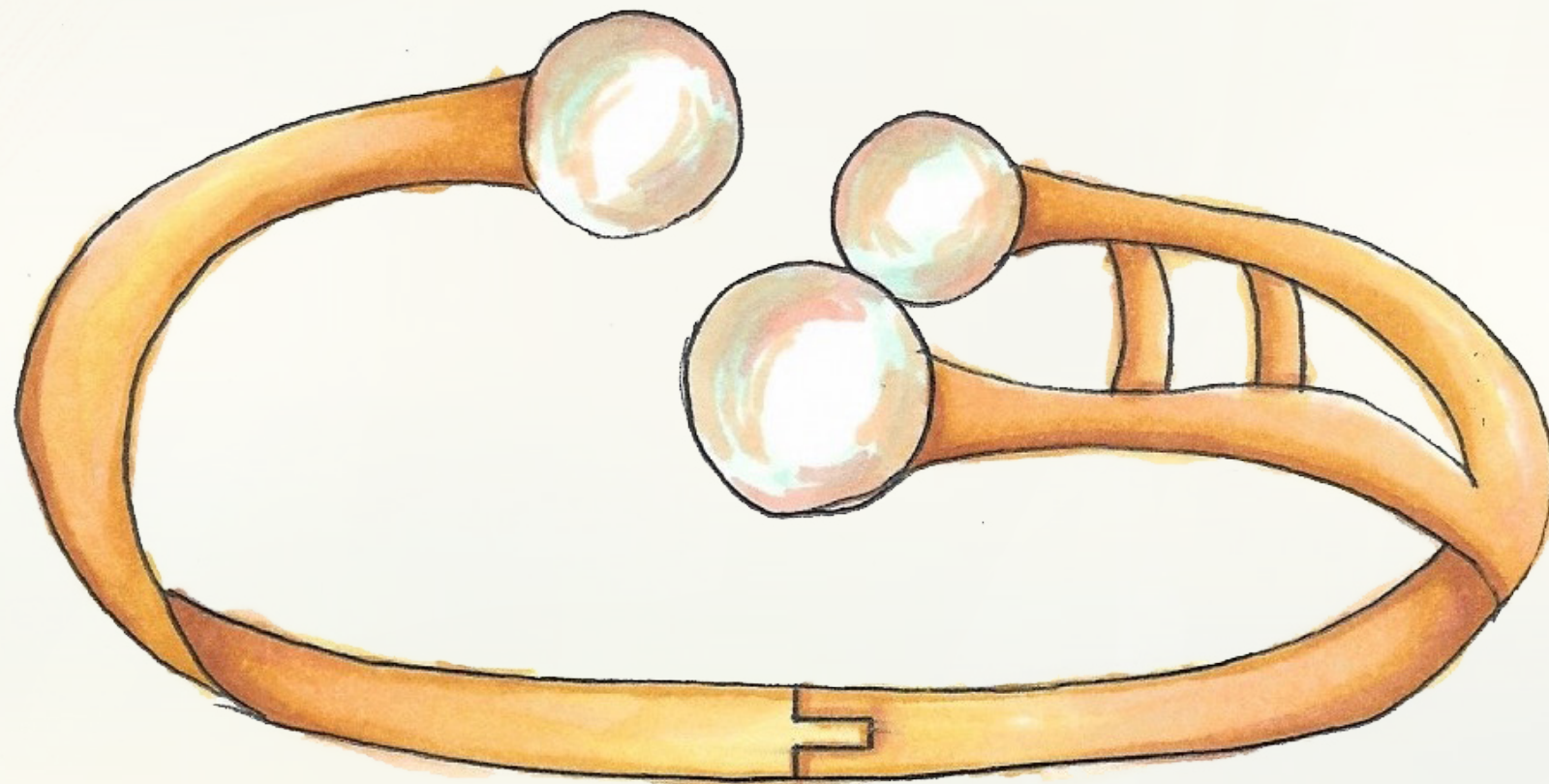
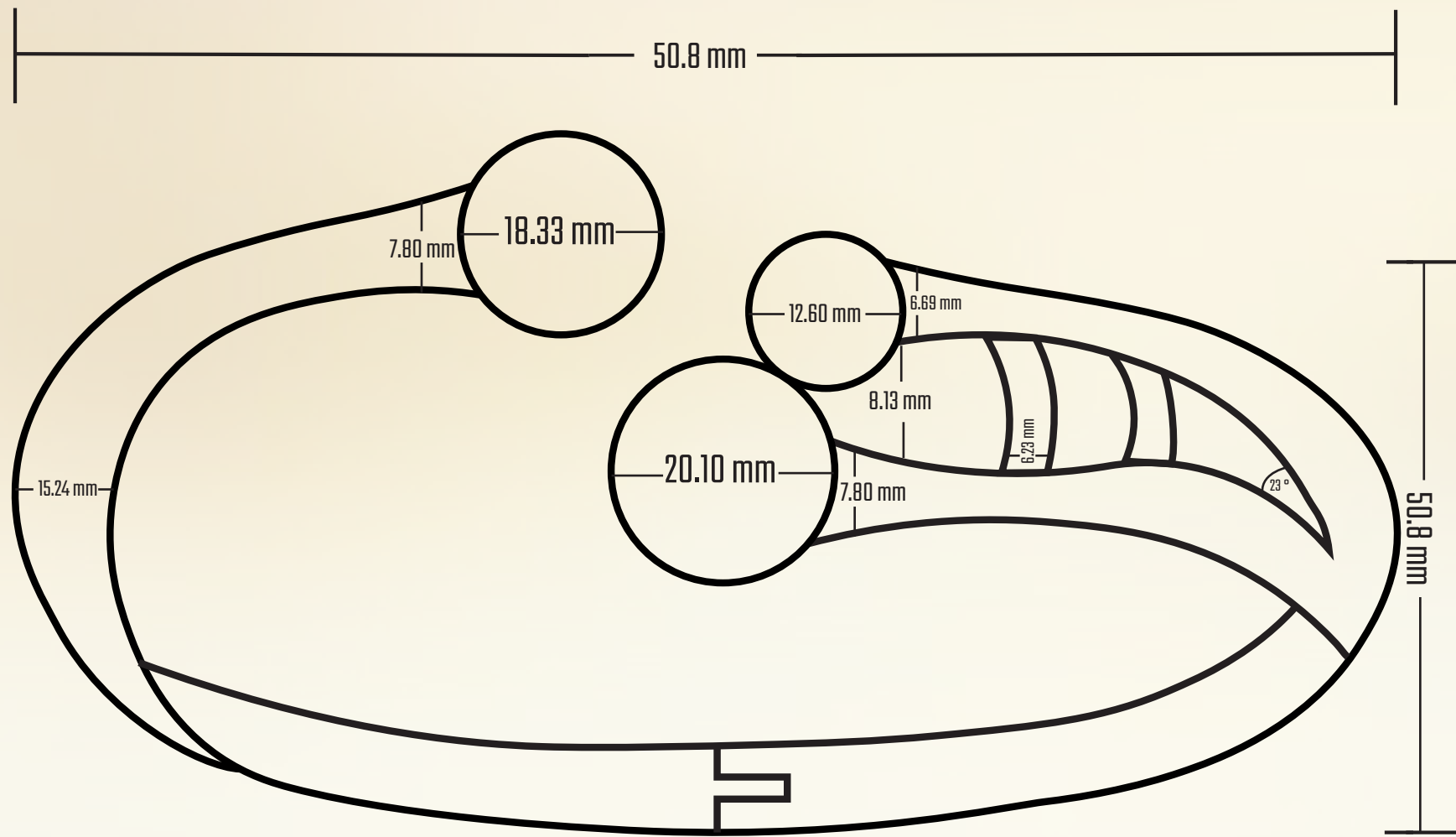

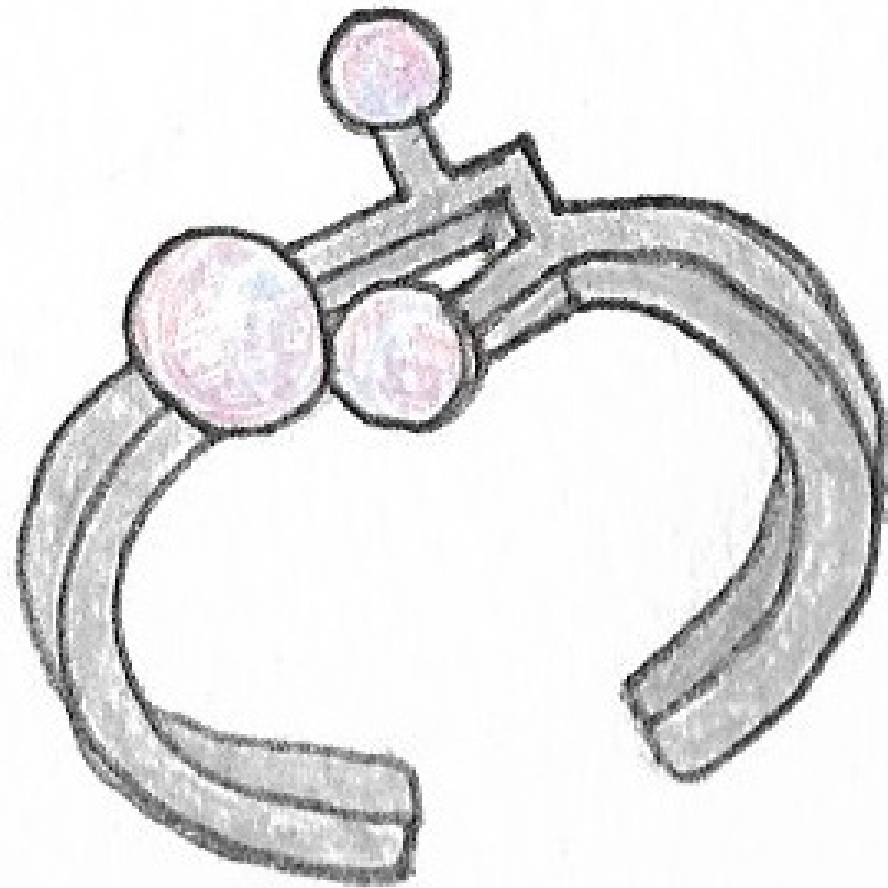
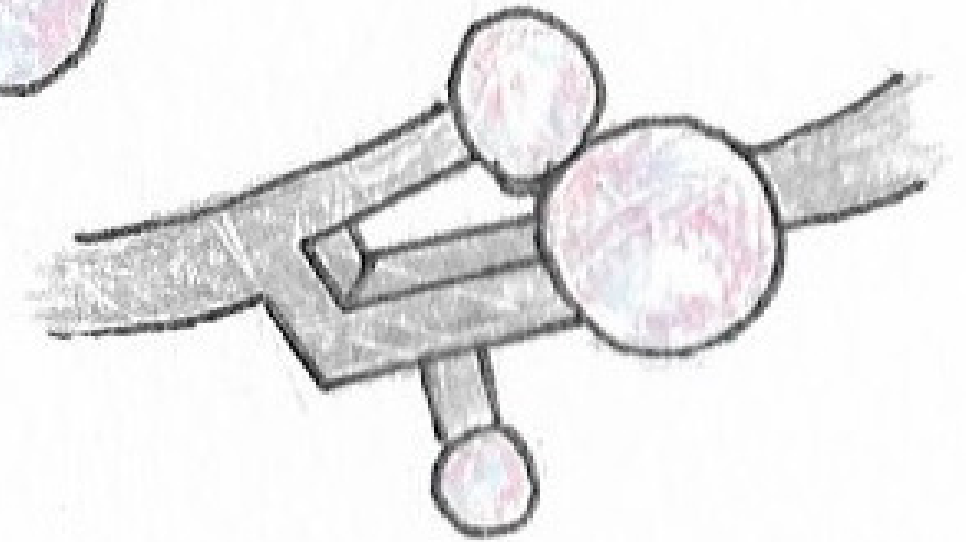
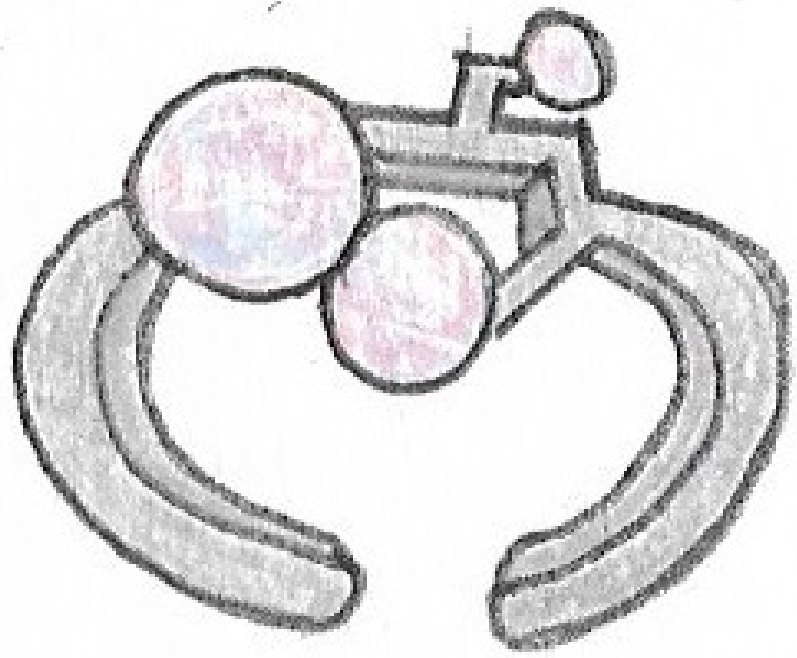

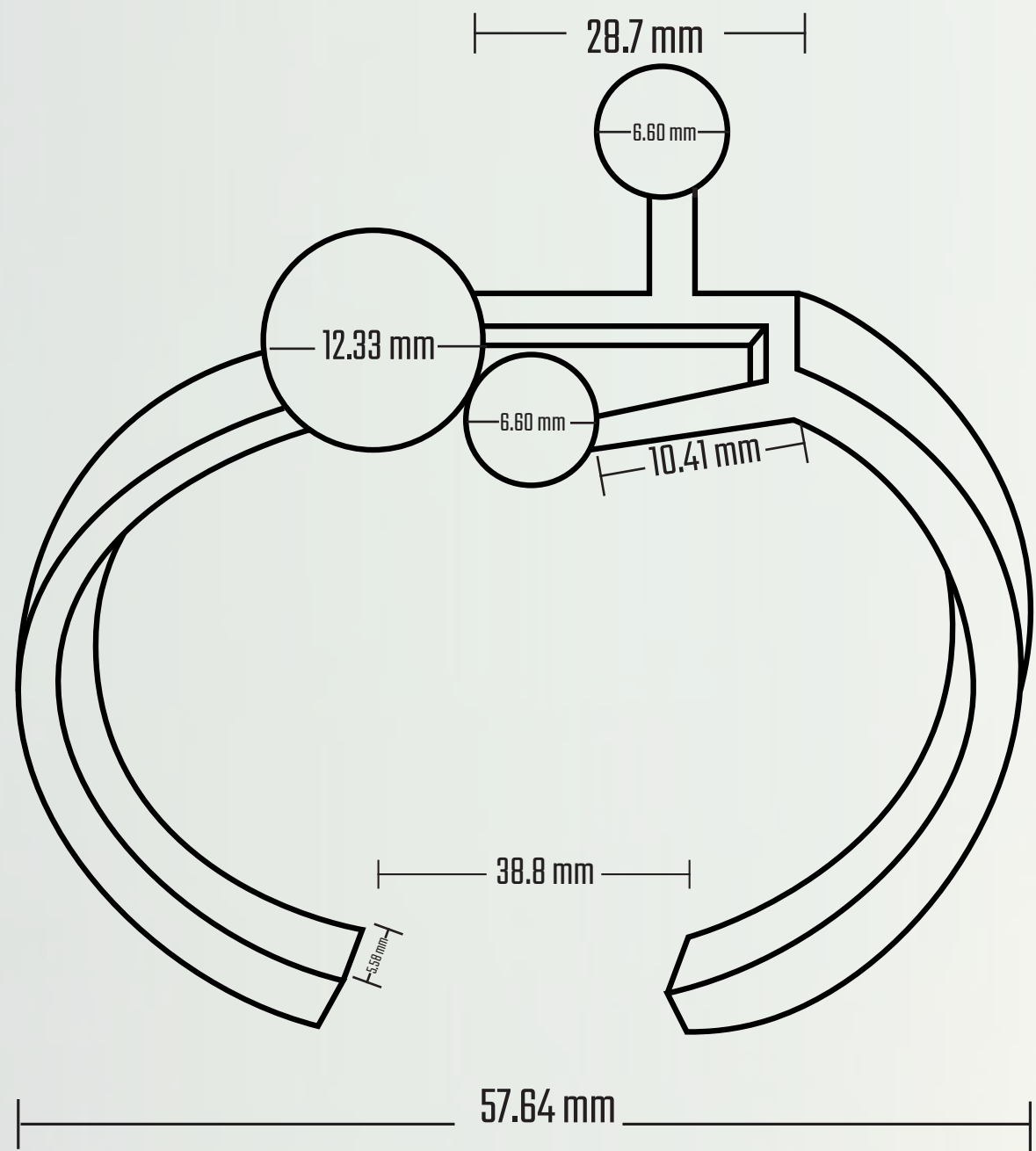

43.12 mm

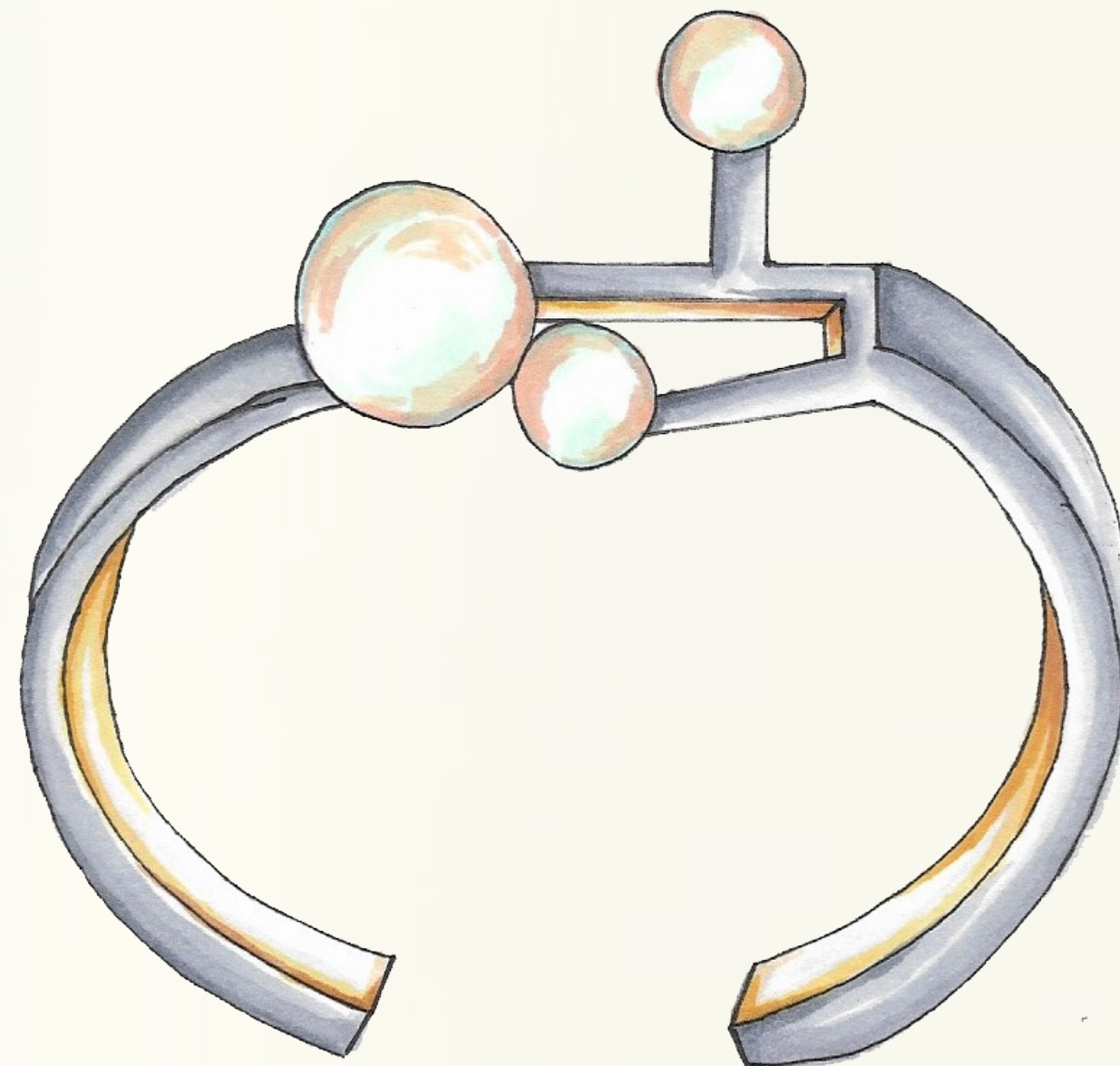

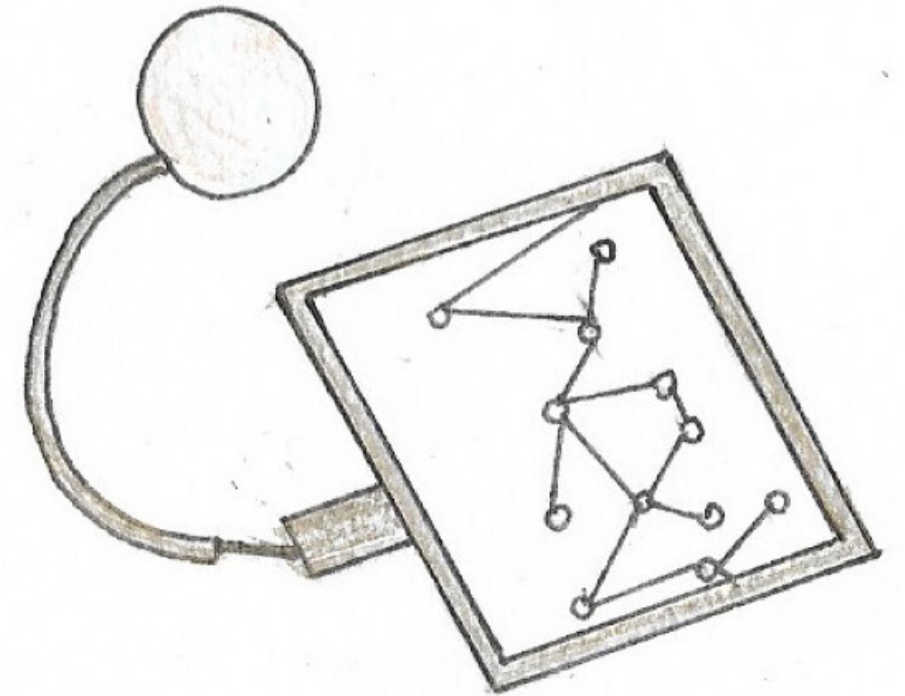
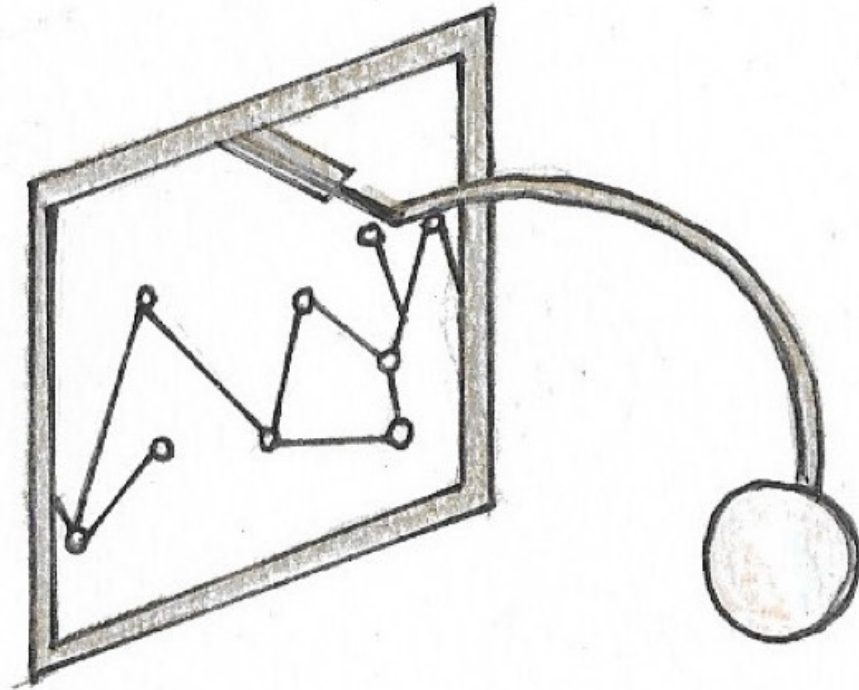
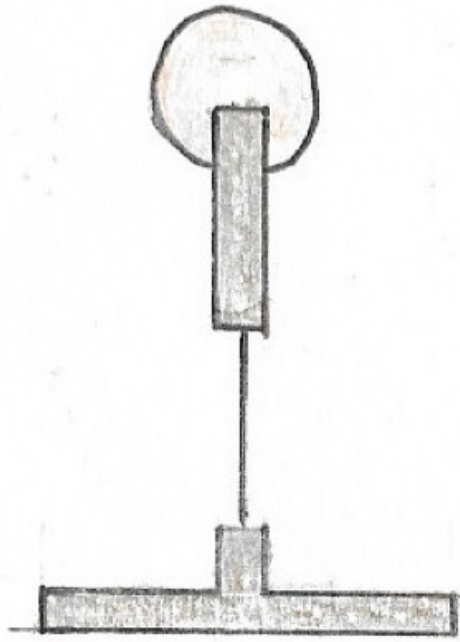
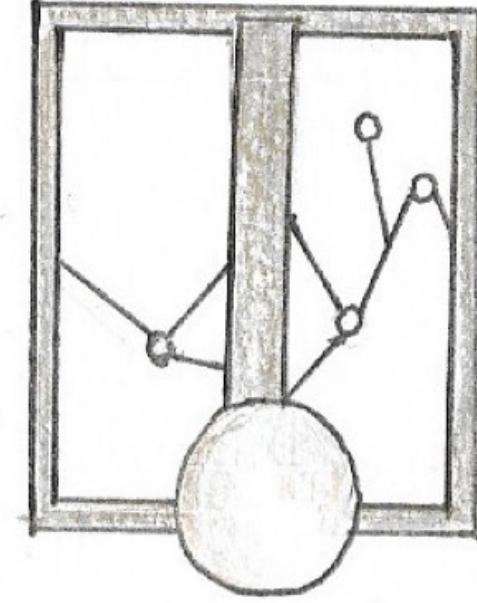
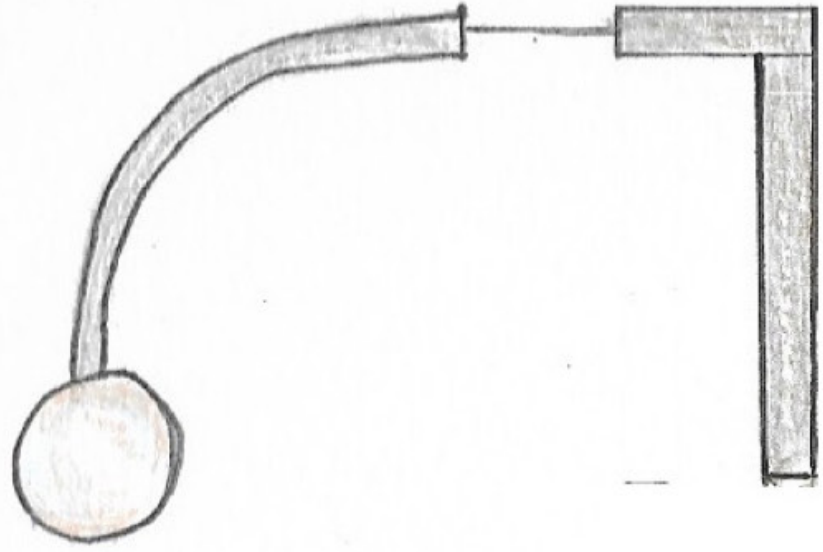

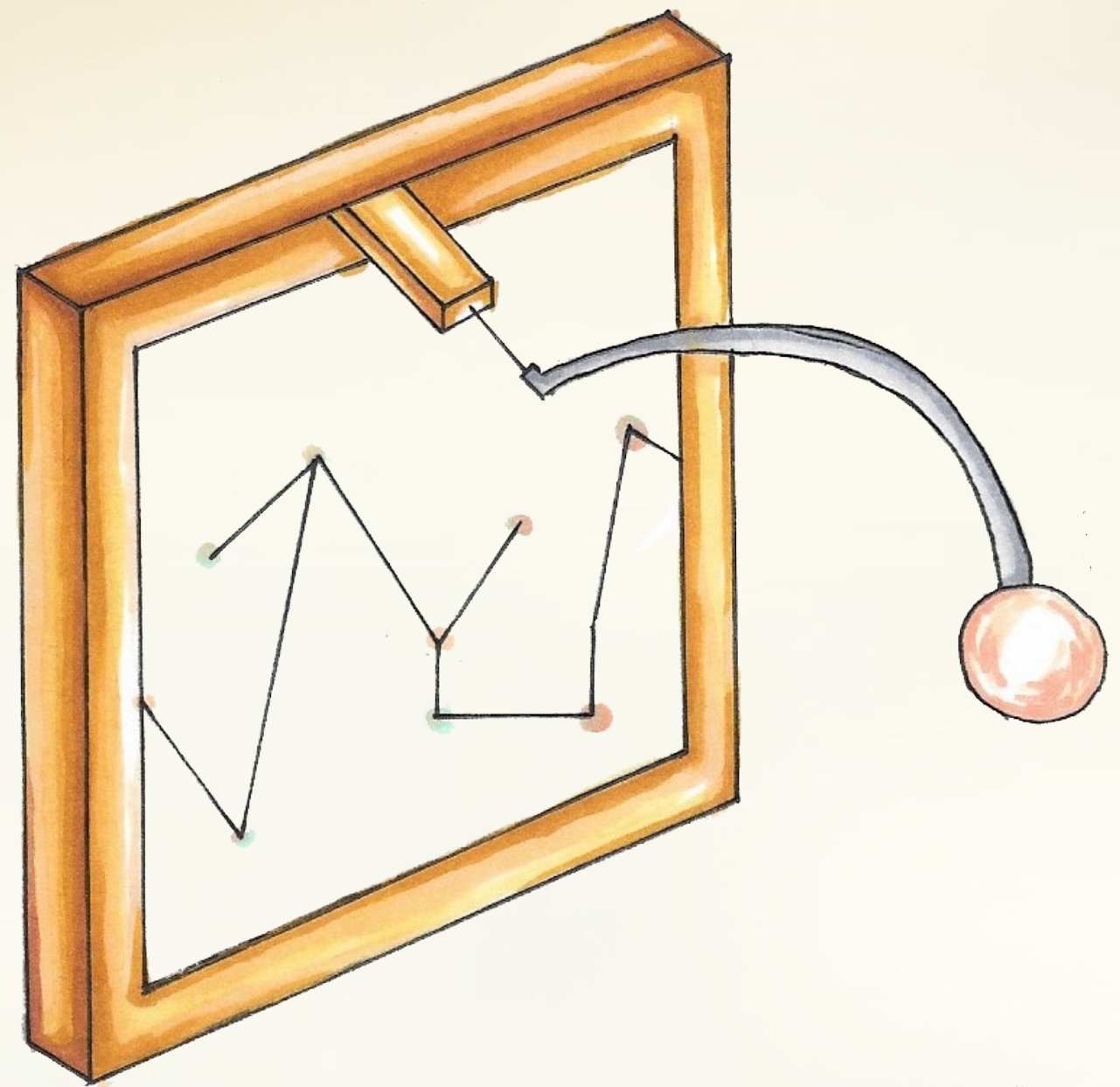
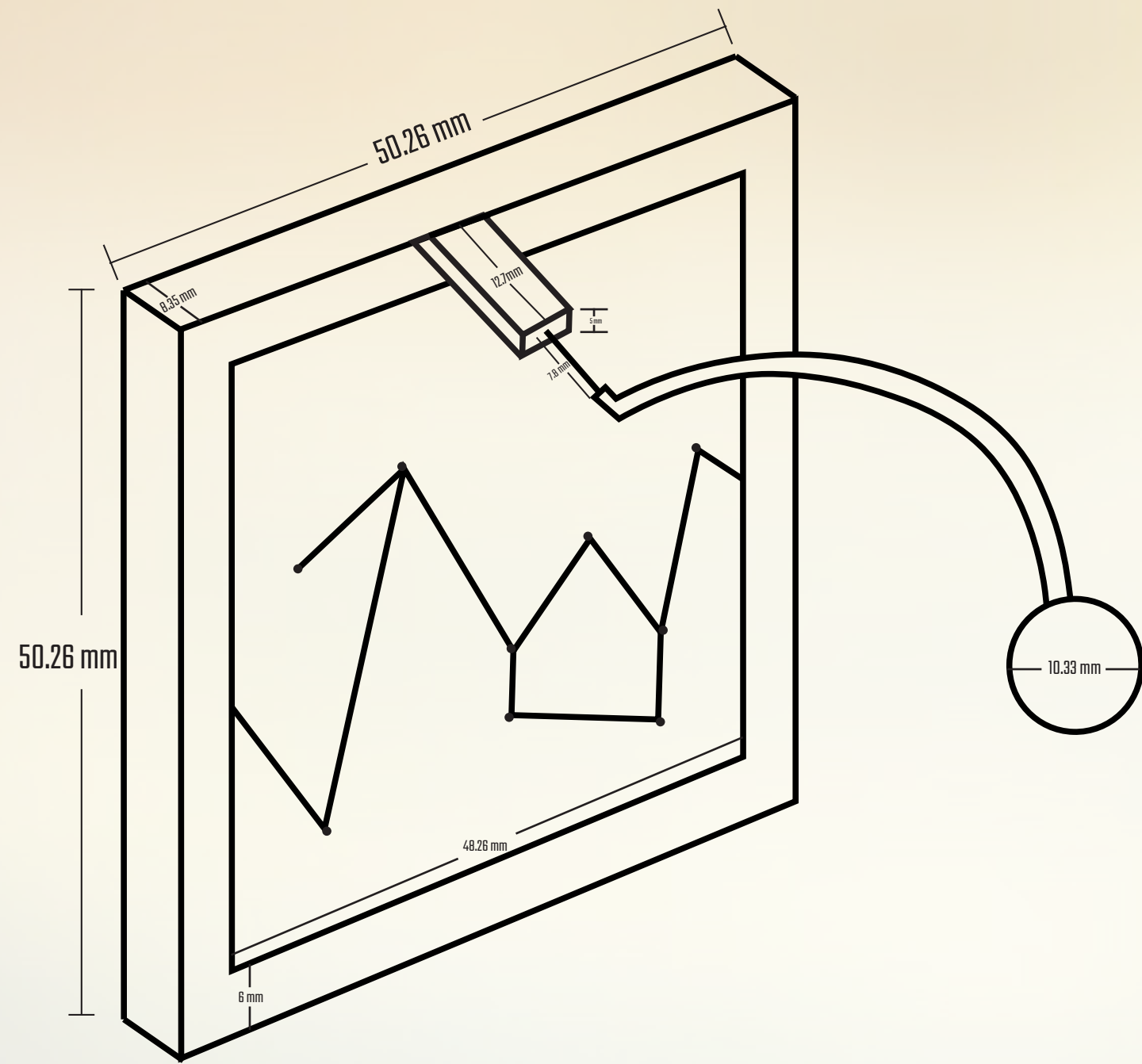

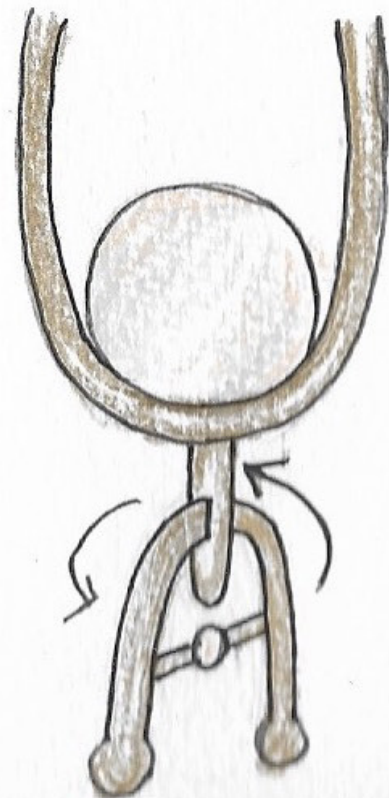
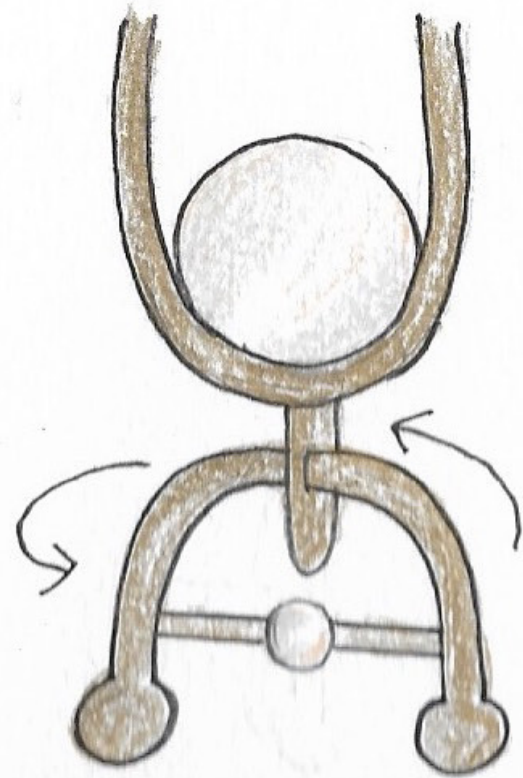
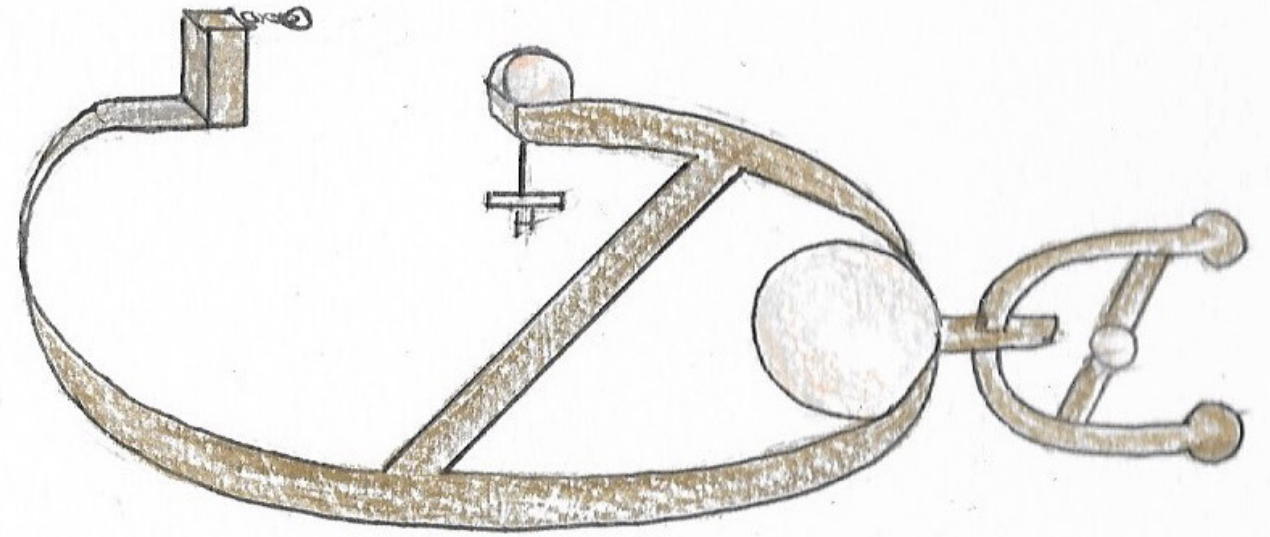
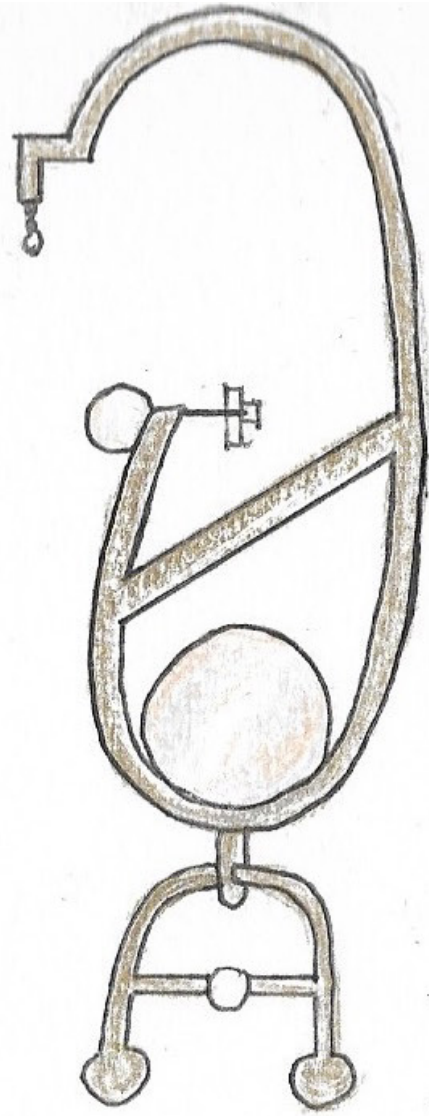

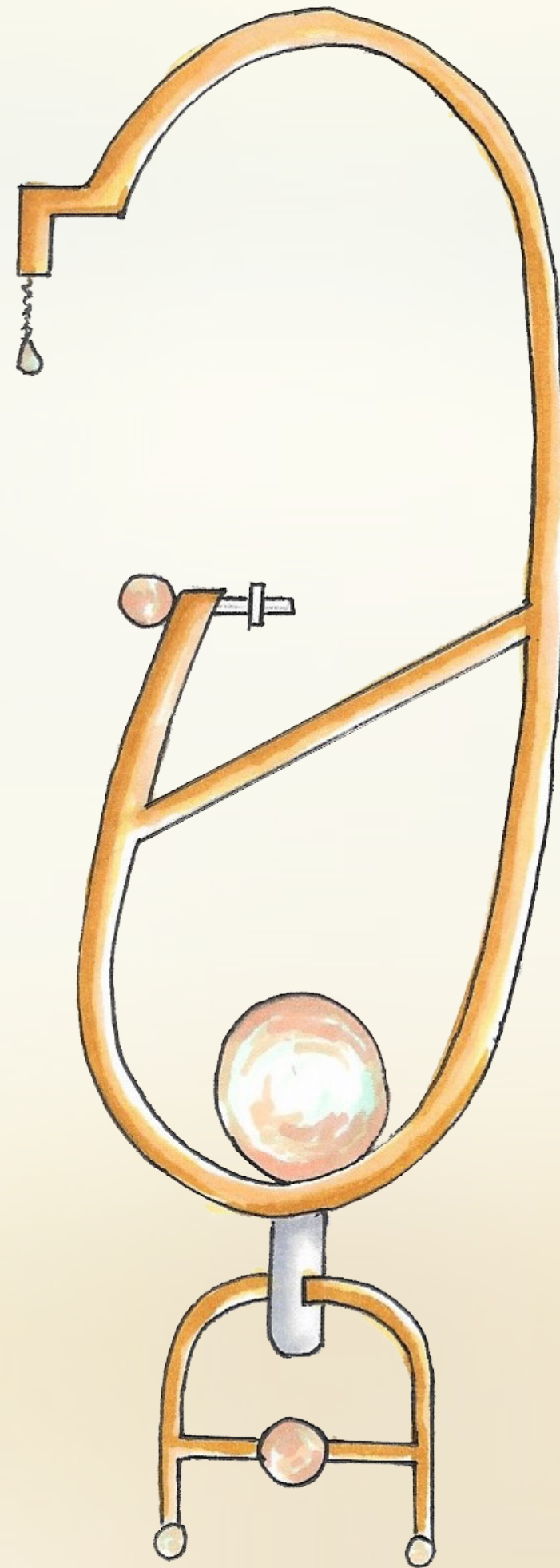
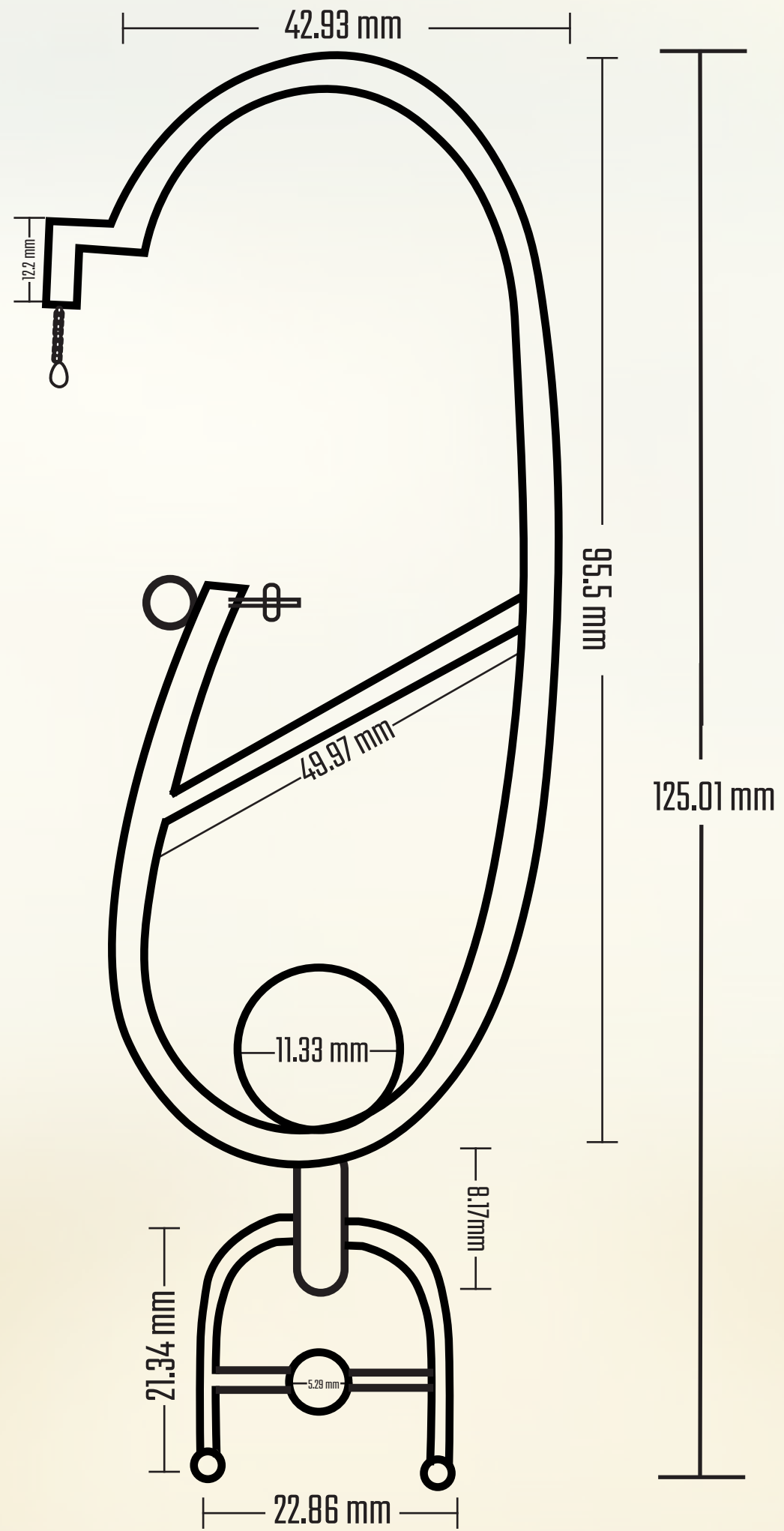

MOOD/REFERENCE OF ENVIRONMENT/LAYOUT



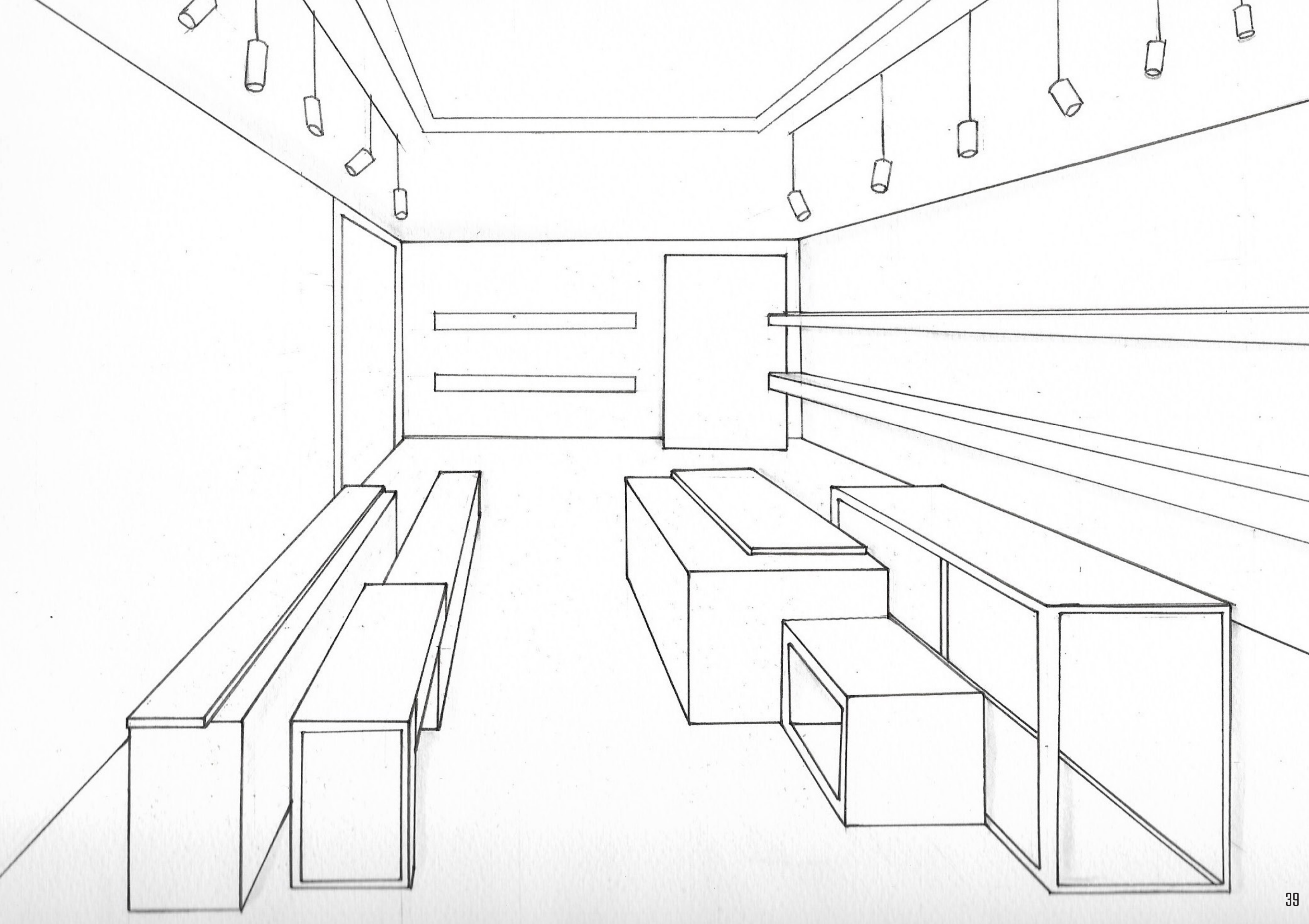
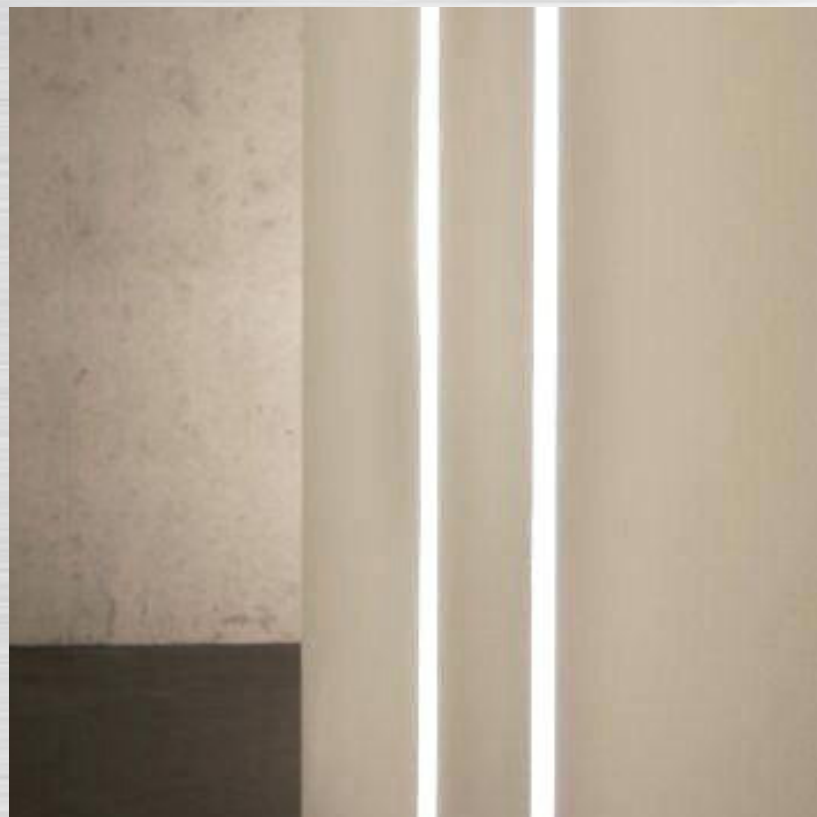



TABLE TOPS:

CALACATTA GOLD BORGHINI EXTRA MARBLE

SOURCE: MSI STONE



CEILING LIGHTS:

HIDDEN CORNER BOX LIGHT

SOURCE: LUMENS



INTERIOR WALLS:

GREY CEMENT TILE OPTICAL

SOURCE: MOSAFIL FRANCE

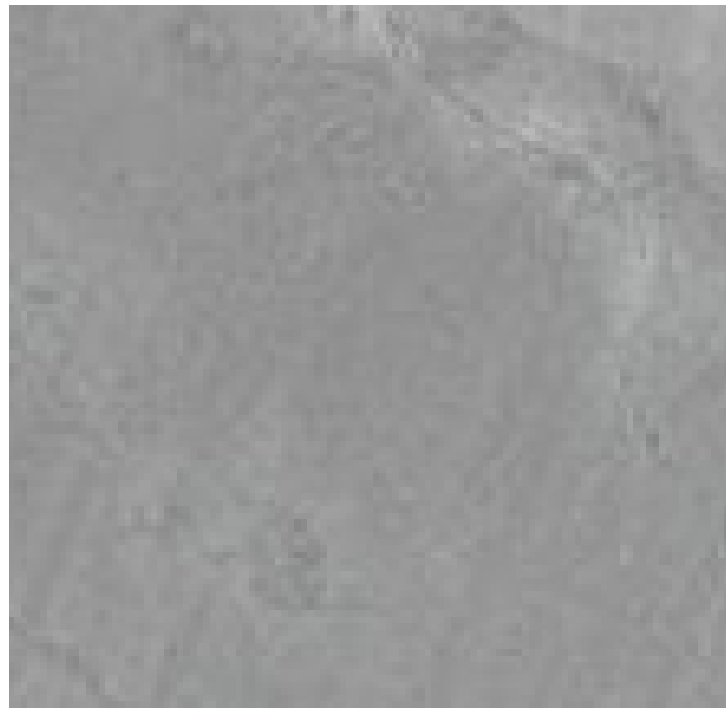

INTERIOR WALLS:

SLATE BURLINGTON SILVER

SOURCE: STONESOURCE

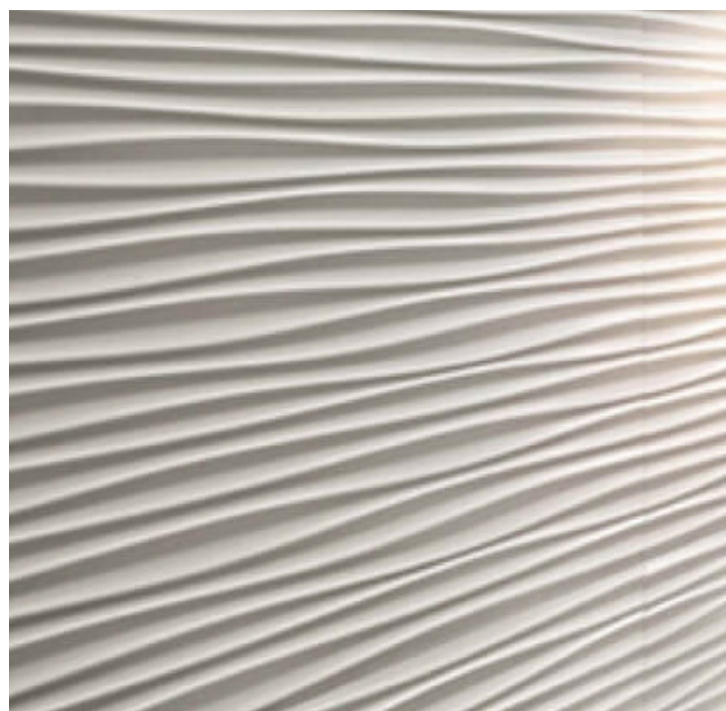

INTERIOR WALLS:

3D DESIGN MATTE FINISH TILE

SOURCE: STONESOURCE

PERFORMANCE: BODY ADORNMENT,
MULTI-FUNCTIONAL/ CONVERTIBLE

ENVIRONMENT: YEAR ROUND PRODUCT

LIFE IN SERVICE : 10+ YEARS (LIFETIME IF USED
AND TAKEN WITH CARE)

MAINTENANCE : STORE IN CARE BAG,
POLISH EVERY 6+ MONTHS FOR EXTRA SHINE

TARGET PRODUCT COST_t: HIGH END MARKET
\$450-\$1500

COMPETITION : HANWEN SHEN DESIGN

PACKING: ACRYLIC CASE + METALLIC BOX

SHIPPING/TRANSPORT: FRAGILE

QUANTITY: LIMITED SUPPLY

MANUFACTURING FACILITY: USA

SIZE: SMALL SCALE

WEIGHT: 0.5 LBS - 4 LBS

AESTHETICS: MINIMAL, SLEEK
FUTURISTIC, ABSTRACT

MATERIALS: PLATINUM, STERLING SILVER, OPAL,
BAROQUE PEARLS, PALLADIUM, BRASS + GOLD PLATING

PRODUCT LIFE SPAN: 10+ YEARS - LIFETIME

STANDARDS/SPECIFICATIONS:

ERGONOMICS: CLOSURE

CUSTOMER: BOLD, DARING, ADVENTUROUS

POLITICAL/SOCIAL IMPLICATIONS:

QUALITY AND RELIABILITY: GUARANTEED

LEGAL:

SHELF LIFE STORAGE: 10+ YEARS - LIFETIME

INSTALLATION:

PROCESSES:

DOCUMENTATION:

TIMESCALE:

DISPOSAL:

TESTING: ERGONOMICS OF PRODUCT, SCALE, SIZING

SAFETY: SHARP S-HOOK CLOSURES

COMPANY CONSTRAINTS:

MARKET CONSTRAINTS:

PATENTS:

PDS/CHECKLIST

